

Section 3

Safety Requirements

A. Safety Appliances and Provisions

1. General

This Section summarizes various safety aspects relevant for the safe operation of a yacht.

2. Guard-Rails

2.1 Location

Efficient guard-rails or bulwarks are to be fitted on all exposed parts of the freeboard and superstructure decks.

2.2 Heights

The height is to be at least 1,0 m from the deck (in exceptional cases for yachts of a length $L \leq 48$ m at least 600 mm from the deck).

It is recommended that on each side of the yacht a toe rail at least 20 mm high is provided along the deck edge.

The height below the lowest course of the guard-rails is not to exceed 230 mm. The other courses are not to be spaced more than 380 mm apart.

2.3 Wires

Guard-rails shall consist of multi strand steel wire provided with a relevant plastic cover and equipped with a device to control their tension in an easy way. The minimum thickness of the top rail shall be at least 10 mm. The thickness of the lower rails may be reduced by 40 %, but must be not less than 6 mm dia.

2.4 Stanchions

Guard-rail stanchions must not be more than 2,15 m apart. In case of yachts with rounded gunwales, the guard-rail supports are to be placed on the flat part of the deck. Stanchion feet must be bolted through or welded down, but may not be welded on the shell plating.

2.4.1 For yachts with $24 \text{ m} \leq L \leq 48 \text{ m}$ stanchions shall have the following minimum section modulus at the foot:

$$W = h \cdot \frac{300 \cdot a + 100}{R_{eH}}$$

a = stanchion spacing [m]

h = stanchion height [m]

R_{eH} = upper yield strength of material [N/mm²]

2.4.2 For yachts with $L > 48$ m reference is made to the GL Rules [Part 1 – Seagoing Ships, Chapter 1 – Hull Structures, Section 21](#) regarding requirements of guard rails.

3. Access to the rig and bowsprit

Special measures are to be taken for safe access to rig and bowsprit and also for safe working thereon regarding operation, maintenance, surveys, etc.

4. Lifting appliances

4.1 The determination of scantlings and checking of lifting gear is not part of Classification.

4.2 Approval of the hull structure in way of the lifting gear taking into account the forces from the gear is part of Classification.

Note

In all cases where GL is entrusted with the judgement of lifting gears of yachts, the GL Rules VI – Additional Rules and Guidelines, Part 2 – Lifting Appliances, Chapter 2 – Guidelines for the Construction and the Survey of Lifting Appliances will apply. Launching appliances are to comply with Chapter 1 of the above rules.

B. Structural Fire Protection

1. General

1.1 Purpose

The purpose of these Rules is to recommend design criteria, construction standards and other safety measures concerning the structural fire protection of yachts with a length $L \geq 24$ m.

1.2 Equivalence

Ships deviating partly from the requirements of these Rules may be assigned Class if the arrangements, material or equipment which have been applied are considered equivalent to those of the Rules.

1.3 Definitions

The meaning of terms and phrases used in these Rules corresponds with the definitions as stated in the relevant chapters of SOLAS 74 as amended.

2. Yachts under 500 GT and $L \leq 48$ m

2.1 Structural integrity

2.1.1 Machinery spaces, galleys and storerooms containing inflammable substances shall be surrounded by divisions of steel or shall be protected by other equivalent methods.

2.1.2 Boundaries of control stations and of machinery spaces containing internal combustion machinery or other oil-burning, heating or pumping units shall be equal to an "A-60" standard, but may be reduced to "A-30" or "A-0" if the ship operates in restricted or protected waters respectively. In case the adjacent spaces are of negligible fire risk, the fire integrity of the divisions needs not to exceed the "A-0" standard.

2.1.3 Escape routes shall be separated from adjacent spaces by at least class B divisions.

2.2 Fire protection materials and details of construction

2.2.1 In general insulating materials shall be non-combustible. Where combustible insulation material is used in accessible spaces in which a fire might occur, it shall be covered with materials having at least approved low-flame spread characteristics.

2.2.2 In spaces where the penetration of oil products is possible, the surface of insulation shall be impervious to oil or oil vapors.

2.2.3 Combustible material if used for partitions, ceilings or linings requires adequate alternative measures of fire protection. Alternative measures might be for example the installation of a fixed fire detection and fire alarm system or of an automatic sprinkler, fire detection and fire alarm system.

2.2.4 Paints, varnishes and other finishes used on exposed interior surfaces are to be of an approved low flame-spread type and shall not be capable of producing excessive quantities of smoke and toxic products.

2.3 Ventilation

As far as practicable ventilation systems shall meet the requirements of 3.10. In any case the standard of the GL Rules [Part 3 – Special Craft, Chapter 3 – Yachts and Boats up to 24 m](#) shall be met at least.

2.4 Means of Escape

2.4.1 As far as practicable the means of escape shall meet the requirements in 3.11. In any case the standard of the provisions in 2.4.2 to 2.4.4 shall be met at least.

2.4.2 Stairways and ladders shall be arranged to provide ready means of escape to the open deck and then to the survival craft from all accommodation, service and other spaces which may normally be occupied.

2.4.3 As far as practicable not less than two means of escape shall be provided. Dead-end situations exceeding 7 m in length shall be avoided in any case. Accommodation spaces or groups of spaces shall have two means of escape unless there is a means of escape that leads directly to the open deck.

2.4.4 Below the lowest open deck at least one means of escape shall be independent of watertight doors.

3. Yachts of 500 GT and over and $L > 48$ m

3.1 General

The requirements of 3. are additional to those of 2. The requirements of 3. take precedence over 2.

3.2 Structural integrity

3.2.1 The hull, superstructures, structural bulkheads, decks and deckhouses shall be constructed of steel or other equivalent material. Special fire protection precautions are required if parts or all of the aforementioned structural elements are consisting of materials other than steel or other equivalent material.

3.2.2 Unless otherwise specified in 2.2.1, in cases where any part of the structure is of aluminium alloy, the following shall apply:

- The insulation of aluminium alloy components of "A" or "B" class divisions, except structure which, in the opinion of GL, is non-load-bearing, shall be such that the temperature of the structural core does not rise more than 200 °C above the ambient temperature at any time during the applicable fire exposure to the standard fire test.
- Special attention shall be given to the insulation of aluminium alloy components of columns, stanchions and other structural members required to support lifeboat and liferaft stowage, launching and embarkation areas, and A and B class divisions to ensure:

- that for such members supporting lifeboat and liferaft areas and "A" class divisions, the temperature rise limitation specified in above shall apply at the end of one hour
- that for such members required to support B class divisions, the temperature rise limitation specified in above shall apply at the end of half an hour.

3.2.3 Crowns and casings of machinery spaces of category A shall be of steel construction and shall be insulated as required by Table 3.1, as appropriate. For vessels under 1 000 GT the steel construction is not required provided the relevant divisions are of "A-60" standard and an approved method for boundary cooling is available that operates also under emergency power supply.

3.2.4 The floor plating of normal passageways in machinery spaces of category A shall be made of steel.

3.2.5 Materials readily rendered ineffective by heat shall not be used for overboard scuppers, sanitary discharges, and other outlets which are close to the waterline and where the failure of the material in the event of fire would give rise to danger of flooding.

3.3 Main vertical zones and horizontal zones

3.3.1 The hull, superstructure and deckhouses in way of accommodation and service spaces shall be subdivided into main vertical zones by "A" class divisions, the mean length and width of which on any deck does not in general exceed 40 m. These divisions shall have insulation values in accordance with Tables 3.1 and 3.2.

3.3.2 As far as practicable, the bulkheads forming the boundaries of the main vertical zones above the bulkhead deck shall be in line with watertight subdivision bulkheads situated immediately below the bulkhead deck. The length and width of main vertical zones may be extended to a maximum of 48 m in order to bring the ends of main vertical zones to coincide with watertight subdivision bulkheads or in order to accommodate a large public space extending for the whole length of the main vertical zone provided that the total area of the main vertical zone is not greater than 1 600 m² on any deck. The length or width of a main vertical zone is the maximum distance between the furthestmost points of the bulkheads bounding it.

3.3.3 Such bulkheads shall extend from deck to deck and to the shell or other boundaries.

3.3.4 Where a main vertical zone is subdivided by horizontal "A" class divisions into horizontal zones for the purpose of providing an appropriate barrier between a zone with sprinklers and a zone without sprinklers, the divisions shall extend between adjacent

main vertical zone bulkheads and to the shell or exterior boundaries of the ship and shall be insulated in accordance with the fire insulation and integrity values given in Table 3.2.

3.4 Fire integrity of bulkheads and decks

3.4.1 Yachts shall be subdivided into spaces by thermal and structural divisions having regard to the fire risk of the space.

3.4.2 Bulkheads required to be "B" class divisions shall extend from deck to deck and to the shell or other boundaries. However, where a continuous "B" class ceiling or lining is fitted on both sides of the bulkhead, the bulkhead may terminate at the continuous ceiling or lining.

3.4.3 Bulkheads not required to be "A" or "B" class divisions, shall be at least "C" class construction.

3.4.4 In addition to complying with the specific provisions for the fire integrity of bulkheads and decks, the minimum fire integrity of bulkheads and decks shall be as described in Tables 3.1 and 3.2.

In the Tables 3.1 and 3.2 the classification of space use is defined using the following numbers for different types of spaces:

[1] Control stations

Spaces containing emergency sources of power and lighting, wheelhouse and chartroom, spaces containing the ship's radio equipment, fire control stations, control room for propulsion machinery when located outside the machinery space, spaces containing centralized fire alarm equipment

[2] Corridors

Corridors and lobbies

[3] Accommodation spaces

Spaces used for public spaces, lavatories, cabins, offices, hospitals, cinemas, game and hobby rooms, barber shops, pantries containing no cooking appliances and similar spaces

[4] Stairways

Interior stairway, lifts, totally enclosed emergency escape trunks, and escalators (other than those wholly contained within the machinery spaces) and enclosures thereto. In this connection, a stairway which is enclosed only at one level shall be regarded as part of the space from which it is not separated by a fire door

[5] Service spaces (low risk)

Lockers and store-rooms not having provisions for the storage of flammable liquids and having areas less than 4 m² and drying rooms and laundries

Table 3.1 Bulkheads separating adjacent spaces

Space above		[1]	[2]	[3]	[4]	[5]	[6]	[7]	[8]	[9]	[10]
Space below											
Control stations	[1]	A-0 _c	A-0	A-60	A-15	A-0	A-60	A-15 _g	A-60	A-60	*
Corridors	[2]		C _c	B-0 _c	A-0 _a	B-0 _c	A-60	A-0	A-0 _d	B-0 _{d,f}	*
Accommodation spaces	[3]			C _c	A-0 _a	B-0 _c	A-60	A-0	A-0 _d	B-0 _{d,f}	*
Stairways	[4]				A-0 _a	A-0 _a	A-60	A-0	A-0 _d	A-30	*
Service space (low risk)	[5]					C _c	A-60	A-0	A-0	B-0 _{d,f}	*
Machinery spaces of category A	[6]						*	A-0	A-60	A-60	*
Other machinery [7]spaces	[7]							A-0 _b	A-0	A-0 _{d,g}	*
Service spaces (high risk)	[8]								A-0 _b	A-0 _d	*
Special outfit areas	[9]									d,f	*
Open decks	[10]										—

Table 3.2 Decks separating adjacent spaces

Space above		[1]	[2]	[3]	[4]	[5]	[6]	[7]	[8]	[9]	[10]
Space below											
Control stations	[1]	A-0	A-0	A-0	A-0	A-0	A-60	A-0	A-0	A-30	*
Corridors	[2]	A-0	*	*	A-0	*	A-60	A-0	A-0	A-30	*
Accommodation spaces	[3]	A-60	A-0	*	A-0	*	A-60	A-0	A-0	A-30	*
Stairways	[4]	A-0	A-0	A-0	*	A-0	A-60	A-0	A-0	A-30	*
Service space (low risk)	[5]	A-0	A-0	A-0	A-0	*	A-60	A-0	A-0	A-30	*
Machinery spaces of category A	[6]	A-60	A-60	A-60	A-60	A-60	*	A-60 _g	A-60	A-60	*
Other machinery [7] spaces	[7]	A-15 _g	A-0	A-0	A-0	A-0	A-0	*	A-0	A-30 _g	*
Service spaces (high risk)	[8]	A-60	A-0 _d	A-0 _d	A-0 _d	A-0	A-60	A-0	A-0	A-30	*
Special outfit areas	[9]	A-60	A-30	A-30	A-30	A-30	A-60	A-30 _g	A-30	A-30	*
Open decks	[10]	*	*	*	*	*	*	*	*	*	—

- a For boundaries of stairways connecting only two decks and being not part of a main vertical zone division "A-0" may be reduced to B-0.
- b Where spaces are of the same numerical category and subscript b appears, a bulkhead or a deck of the rating shown in the tables is only required when the adjacent spaces are of a different purpose, e.g. in category (8). A galley next to a galley does not require a bulkhead but a galley next to a paint room requires an "A-0" bulkhead.
- c Bulkheads separating the wheelhouse and the chartroom from each other may be of "B-0" rating.
- d For main vertical zone divisions "A-0", "B-0" and the dash, where appearing in the tables, shall be read as "A-30".
- e For main vertical zone divisions "B-0" and "C", where appearing in the tables, shall be read as "A-0".
- f In case of deck opening enclosures for stairways, lifts, trunks, etc. being part of special outfit areas "B-0" and the dash, where appearing in the tables, shall be read as "A-30".
- g Fire insulation need not be fitted if, in the opinion of GL, the machinery space of category [7] has little or no fire risk.
- * Where an asterisk appears in the tables, the division is required to be of steel or other equivalent material but is not required to be of "A" class standard. However, where a deck, except an open deck, is penetrated for the passage of electric cables, pipes and vent ducts, such penetrations should be made tight to prevent the passage of flame and smoke. Divisions between control stations (emergency generators) and open decks may have air intake openings without means for closure, unless a fixed gas fire-fighting system is fitted.
For decks being part of a main vertical zone division an asterisk, where appearing in the tables, shall be read as "A-0".
Special fire protection precautions are to be taken in case relevant boundaries are not of steel or other equivalent material.

[6] Machinery spaces of category A

Machinery spaces of category A are those spaces and trunks to such spaces which contain either:

- internal combustion machinery used for main propulsion
- internal combustion machinery used for purposes other than main propulsion where such machinery has in the aggregate a total power output of not less than 375 kW; or
- any oil-fired boiler or oil fuel unit, or any oil-fired equipment other than boilers, such as inert gas generators, incinerators, etc.

[7] Other machinery spaces

Machinery spaces containing propulsion machinery, boilers, oil fuel units, steam and internal combustion engines, generators and major electrical machinery, oil filling stations, refrigerating, stabilizing, ventilation and air conditioning machinery, and similar spaces, and trunks to such spaces.

Electrical equipment rooms (auto-telephone exchange, air-conditioning duct spaces)

[8] Service spaces (high risk)

Galleys, pantries containing cooking appliances, saunas, paint lockers and store-rooms having areas of 4 m² or more, spaces for the storage of flammable liquids, and workshops other than those forming part of the machinery spaces.

[9] Special outfit spaces

Spaces as per 3.9

[10] Open decks

Open deck spaces and enclosed promenades having little or no fire risk. To be considered in this category, enclosed promenades shall have no significant fire risk, meaning that furnishings shall be restricted to deck furniture. In addition, such spaces shall be naturally ventilated by permanent openings.

Air spaces (the space outside superstructures and deckhouses).

3.4.5 Continuous "B" class ceilings or linings, in association with the relevant decks or bulkheads, may be accepted as contributing, wholly or in part, to the required insulation and integrity of a division.

3.4.6 External boundaries which are required to be of steel or other equivalent material may be pierced for the fitting of windows and sidescuttles. Similarly, in such boundaries which are not required to have "A" class integrity, doors may be constructed of approved materials other than steel.

3.4.7 Saunas shall comply with the following:

- The perimeter of the sauna shall be of "A" class boundaries and may include changing rooms, showers and toilets. The sauna shall be insulated to "A-60" standard against other spaces except those inside of the perimeter and open deck spaces, sanitary spaces and machinery spaces having little or no fire risk.
- Bathrooms with direct access to saunas may be considered as part of them. In such cases, the door between sauna and the bathroom need not comply with fire safety requirements.
- The traditional wooden lining on the bulkheads and ceiling are permitted in the sauna. The ceiling above the oven shall be lined with a non-combustible plate with an air gap of at least 30 mm. The distance from the hot surfaces to combustible materials shall be at least 500 mm or the combustible materials shall be protected (e.g. non-combustible plate with an air gap of at least 30 mm).
- The traditional wooden benches are permitted to be used in the sauna.
- The sauna door shall open outwards by pushing.
- Electrically heated ovens shall be provided with a timer.

3.4.8 Stairways which penetrate only a single deck shall be protected, at a minimum, at one level by at least "B-0" class divisions and self-closing doors. Lifts which penetrate only a single deck shall be surrounded by "A-0" class divisions with steel doors at both levels. Stairways and lift trunks which penetrate more than a single deck shall be surrounded by at least "A-0" class divisions and be protected by self-closing doors at all levels.

3.4.9 On yachts having accommodation for 12 persons or less, where stairways penetrate more than a single deck and where there are at least two escape routes direct to the open deck at every accommodation level, the "A-0" requirements of 3.4.8 may be reduced to "B-0".

3.5 Penetration in fire-resisting divisions and prevention of heat transmission

3.5.1 Where "A" class divisions are penetrated, such penetrations shall be of an approved type. In case of ventilation ducts 3.10.2 and 3.10.5 apply. However, pipe penetrations made of steel or equivalent material having a thickness of 3 mm or greater and a length of not less than 900 mm (preferably 450 mm on each side of the division), and no openings, is considered as an approved type. Such penetrations shall be suitably insulated by extension of the insulation at the same level as the division.

3.5.2 Where "B" class divisions are penetrated for the passage of electric cables, pipes, trunks, ducts, etc., or for the fitting of ventilation terminals, lighting fixtures and similar devices, arrangements shall be made to ensure that the fire resistance is not impaired, subject to the provisions of 3.10.6. Pipes other than steel or copper that penetrate "B" class divisions shall be protected by either:

- an approved penetration device, suitable for the fire resistance of the division pierced and the type of pipe used; or
- a steel sleeve, having a thickness of not less than 1,8 mm and a length of not less than 900 mm for pipe diameters of 150 mm or more and not less than 600 mm for pipe diameters of less than 150 mm (preferably equally divided to each side of the division). The pipe shall be connected to the ends of the sleeve by flanges or couplings; or the clearance between the sleeve and the pipe shall not exceed 2,5 mm; or any clearance between pipe and sleeve shall be made tight by means of non-combustible or other suitable material.

3.5.3 Uninsulated metallic pipes penetrating "A" or "B" class divisions shall be of materials having a melting temperature which exceeds 950 °C for "A-0" and 850 °C for "B-0" divisions.

3.5.4 With regard to the risk of heat transmission at intersections and terminal points of required thermal barriers, the insulation of a deck or bulkhead shall be carried past the penetration, intersection or terminal point for a distance of at least 450 mm in the case of steel and aluminium structures. If a space is divided with a deck or bulkhead of "A" class standard having insulation of different values, the insulation with the higher value shall continue on the deck or bulkhead with the insulation of the lesser value for a distance of at least 450 mm.

3.6 Doors in fire-resisting divisions

3.6.1 The fire resistance of doors shall be equivalent to that of the division in which they are fitted, this being proved by using doors of an approved type. Doors and door frames in "A" class divisions shall be constructed of steel or other equivalent material. Doors in "B" class divisions shall be non-combustible. Doors fitted in boundary bulkheads of machinery spaces of category A shall be reasonable gas-tight and self-closing. The use of combustible materials in doors separating cabins from individual interior sanitary accommodation, such as showers, may be permitted.

3.6.2 Fire doors in main vertical zone bulkheads and stairway enclosures other than power-operated watertight doors and those which are normally locked shall be self-closing.

3.6.3 Doors required to be self-closing shall not be fitted with hold-back hooks. However, hold-back arrangements as well as power-operated drive facilities fitted with remote release devices of the fail-safe type may be utilized.

3.6.4 In corridor bulkheads ventilation openings may be permitted in and under doors of cabins and public spaces. Ventilation openings are also permitted in B class doors leading to lavatories, offices, pantries, lockers and store rooms. Except as permitted below, the openings shall be provided only in the lower half of the door. Where such an opening is under a door the total net area of any such opening or openings shall not exceed 0,05 m². Alternatively, a non-combustible air balance duct routed between the cabin and the corridor, and located below the sanitary unit is permitted where the cross-sectional area of the duct does not exceed 0,05 m². Ventilation openings, except those under the door, shall be fitted with a grille made of non-combustible material.

3.6.5 Watertight doors need not be insulated.

3.7 Fire protection materials and details of construction

3.7.1 Insulating materials shall be non-combustible, except in baggage rooms and refrigerated compartments of service spaces. Vapor barriers and adhesives used in conjunction with insulation, as well as the insulation of pipe fittings for cold service systems, need not be of non-combustible materials, but they shall be kept to the minimum quantity practicable and their exposed surfaces shall have approved low flame-spread characteristics.

3.7.2 In spaces where penetration of oil products is possible, the surface of insulation shall be impervious to oil or oil vapors.

3.7.3 In accommodation and service spaces and control stations all linings, ceilings, draught stops and their associated grounds shall be of non-combustible materials.

3.7.4 Non-combustible bulkheads, ceilings and linings fitted in accommodation and service spaces may be faced with combustible materials, facings, mouldings, decorations and veneers in accordance with the provisions of 3.7.5 to 3.7.8. However, traditional wooden benches and wooden linings on bulkheads and ceilings are permitted in saunas and such materials need not be subject to the calculations prescribed in 3.7.5 and 3.7.6.

3.7.5 Combustible materials used on the surfaces and linings specified in 3.7.4 shall have a calorific value not exceeding 45 MJ/m² of the area for the thickness used. The requirements of this paragraph are not applicable to the surfaces of furniture fixed to linings or bulkheads.

3.7.6 Where combustible materials are used in accordance with 3.7.4, they shall comply with the following requirements:

- The total volume of combustible facings, mouldings, decorations and veneers in any accommodation and service space not protected by an approved automatic sprinkler, fire detection and fire alarm system shall not exceed a volume equivalent to 2,5 mm veneer on the combined area of the walls and ceiling linings. Furniture fixed to linings, bulkheads or decks need not be included in the calculation of the total volume of combustible materials.
- In the case of yachts fitted with an approved automatic sprinkler, fire detection and fire alarm system, the above volume may include some combustible material used for erection of "C" class divisions.

3.7.7 The following surfaces shall have approved low flame-spread characteristics:

- exposed surfaces in corridors and stairway enclosures and of ceilings in accommodation and service spaces (except saunas) and control stations
- surfaces and grounds in concealed or inaccessible spaces in accommodation and service spaces and control stations

3.7.8 Paints, varnishes and other finishes used on exposed interior surfaces shall not be capable of producing excessive quantities of smoke and toxic products, this being determined in accordance with approved procedures.

3.7.9 Primary deck coverings, if applied within accommodation and service spaces and control stations, shall be of approved material which will not give rise to smoke or toxic or explosive hazards at elevated temperatures, this being determined in accordance with approved procedures.

3.7.10 Primary deck coverings, if applied within accommodation and service spaces and control stations, shall be of approved material which will not readily ignite, this being determined in accordance with approved procedures.

3.7.11 Air spaces enclosed behind ceilings, paneling or linings shall be divided by close-fitting draught stops spaced not more than 14 m apart. In the vertical direction, such enclosed air spaces, including those behind linings of stairways, trunks, etc., shall be closed at each deck.

3.8 Fire detection and alarm

A fixed fire detection and fire alarm system of an approved type shall be so installed and arranged as to

provide smoke detection in all corridors, stairways and escape routes within accommodation spaces, see [Part 1 – Seagoing Ships, Chapter 3 – Electrical Installations, Section 9, D.3.](#)

3.9 Alternative approach to the structural fire protection of accommodation and service spaces with special outfit

3.9.1 In lieu of complying with the requirements of 3.4.3 and 3.7.3 to 3.7.7, the following regulations may apply to restricted areas of accommodation and service spaces with special outfit.

3.9.2 There may be no restriction on the construction of bulkheads not required by this or other regulations to be "A", "B" or "C" class divisions, except in individual cases where fire-rated bulkheads are required in accordance with [Table 3.1.](#)

3.9.3 The boundary decks of special outfit spaces shall be of "A-30" standard, unless 3.4 requires a higher standard. Enclosures of deck openings for stairways, lifts, trunks, etc. are to be protected to the same standard.

3.9.4 Main vertical zone divisions shall be of "A-30" standard if special outfit spaces are adjacent, unless 3.4 requires a higher standard.

3.9.5 Corridors and stairway enclosures serving accommodation and service spaces must not be part of the special outfit areas, unless there are means of escape from those spaces that lead directly to the open deck.

3.9.6 In addition to complying with the specific provisions for the fire integrity of bulkheads and decks, the minimum fire integrity of bulkheads and decks shall be as described in [Tables 3.1 and 3.2.](#)

3.9.7 Areas with special outfit spaces shall be readily accessible for fire-fighting purposes.

3.9.8 An automatic sprinkler, fire detection and fire alarm system of an approved type shall be so installed and arranged as to protect all special outfit spaces, except spaces which afford no substantial fire risk such as void spaces, sanitary spaces, etc. In addition, an approved fixed fire detection and fire alarm system shall be so installed and arranged as to provide smoke detection in the same spaces.

3.9.9 Provided that the area of the special outfit space or spaces is bounded by a continuous "A" or "B" class division not exceeding 50 m², in lieu of complying with the requirements of 3.9.8, a fixed fire detection and fire alarm system of an approved type shall be so installed and arranged as to detect the presence of fire in all special outfit spaces, providing smoke detection in such spaces, except spaces which afford no substantial fire risk such as void spaces, sanitary spaces, etc.

3.10 Ventilation systems

3.10.1 Ventilation ducts shall be of non-combustible material. However, short ducts, not generally exceeding 2 m in length and with a free cross-sectional area not exceeding 0,02 m², need not be non-combustible subject to the following conditions:

- The ducts are made of a material which has low flame-spread characteristics.
- The ducts are only used at the end of the ventilation device.
- The ducts are not situated less than 600 mm, measured along the duct, from an opening in an "A" or "B" class division including continuous "B" class ceiling.

3.10.2 The following arrangements shall be tested in accordance with approved methods:

- fire dampers, including their relevant means of operation
- duct penetrations through "A" class divisions. However, the test is not required where steel sleeves are directly joined to ventilation ducts by means of riveted or screwed flanges or by welding.

3.10.3 The ventilation systems for machinery spaces of category A and galleys shall, in general, be separated from each other and from the ventilation systems serving other spaces. Except that the galley ventilation systems on ships of less than 4 000 gross tonnage, need not be completely separated, but may be served by separate ducts from a ventilation unit serving other spaces. In any case, an automatic fire damper shall be fitted in the galley ventilation duct near the ventilation unit. Ducts provided for the ventilation of machinery spaces of category A or galleys shall not pass through accommodation spaces, service spaces or control stations unless they comply with the conditions specified as follows:

- The ducts are constructed of steel having a thickness of at least 3 mm and 5 mm for ducts the widths or diameters of which are up to and including 300 mm and 760 mm and over respectively and, in the case of such ducts, the widths or diameters of which are between 300 mm and 760 mm having a thickness obtained by interpolation.
- The ducts are to be suitably supported and stiffened.
- The ducts are fitted with automatic fire dampers close to the boundaries penetrated.
- The ducts are insulated to "A-60" class standard from the machinery spaces or galleys to a point at least 5 m beyond each fire damper.

Alternatively:

- The ducts are constructed of steel in accordance with the first and second item of 3.10.3.
- The ducts are insulated to "A-60" class standard throughout the accommodation spaces, service spaces or control stations; except that penetrations of main zone divisions shall also comply with the requirements of 3.8.

3.10.4 Ducts provided for ventilation to accommodation spaces, service spaces or control stations shall not pass through machinery spaces of category A and galleys unless they comply with the conditions specified as follows:

- The ducts where they pass through a machinery space of category A or galley are constructed of steel in accordance with the first and second item of 3.10.3.
- Automatic fire dampers are fitted close to the boundaries penetrated.
- The integrity of the machinery space or galley boundaries is maintained at the penetrations.

Alternatively:

- The ducts where they pass through a machinery space of category A or galley are constructed of steel in accordance with the first and second item of 3.10.3.
- The ducts are insulated to "A-60" standard within the machinery space or galley; except that penetrations of main zone divisions shall also comply with the requirements of 3.8.

3.10.5 Where a thin plated duct with a free cross-sectional area equal to, or less than, 0,02 m² passes through "A" class bulkheads or decks, the opening shall be lined with a steel sheet sleeve having a thickness of at least 3 mm and a length of at least 200 mm, divided preferably into 100 mm on each side of the bulkhead or, in the case of the deck, wholly laid on the lower side of the decks pierced.

Where ventilation ducts with a free cross-sectional area exceeding 0,02 m² pass through "A" class bulkheads or decks, the opening shall be lined with a steel sheet sleeve. However, where such ducts are of steel construction and pass through a deck or bulkhead, the ducts and sleeves shall comply with the following:

- The sleeves shall have a thickness of at least 3 mm and a length of at least 900 mm. When passing through bulkheads, this length shall be divided preferably into 450 mm on each side of the bulkhead. These ducts, or sleeves lining such ducts, shall be provided with fire insulation. The insulation shall have at least the same fire integrity as the bulkhead or deck through which the duct passes.

- Ducts with a free cross-sectional area exceeding 0,075 m² shall be fitted with a fire damper in addition to the requirements of the above item. The fire damper shall operate automatically, but shall also be capable of being closed manually from both sides of the bulkhead or deck. The damper shall be provided with an indicator which shows whether the damper is open or closed. Fire dampers are not required, however, where ducts pass through spaces surrounded by "A" class divisions, without serving those spaces, provided those ducts have the same fire integrity as the divisions which they pierce. Fire dampers shall be easily accessible. Where they are placed behind ceilings or linings, these ceilings or linings shall be provided with an inspection door on which a plate reporting the identification number of the fire damper is provided. The fire damper identification number shall also be placed on any remote controls required.

3.10.6 Ventilation ducts with a free cross-sectional area exceeding 0,02 m² passing through "B" class bulkheads shall be lined with steel sheet sleeves of 900 mm in length divided preferably into 450 mm on each side of the bulkhead, unless the duct is of steel for this length.

3.10.7 In general, the ventilation fans shall be so disposed that the ducts reaching the various spaces remain within the same main vertical zone.

3.10.8 Where it is necessary that a ventilation duct passes through a main vertical zone division, a fail-safe automatic closing fire damper shall be fitted adjacent to the division. The damper shall also be capable of being manually closed from each side of the division. The operating position shall be readily accessible and be marked in red light-reflecting color. The duct between the division and the damper shall be of steel or other equivalent material and, if necessary, insulated to comply with the requirements of 3.5.1. The damper shall be fitted on at least one side of the division with a visible indicator showing whether the damper is in the open position.

3.10.9 Where ventilation systems penetrate decks, precautions shall be taken, in addition to those relating to the fire integrity of the deck required by 3.5.1, to reduce the likelihood of smoke and hot gases passing from one tween-deck space to another through the system. In addition to insulation requirements contained in this paragraph, vertical ducts shall, if necessary, be insulated as required by Table 3.1 or 3.2 as appropriate.

3.10.10 Practicable measures shall be taken for control stations outside machinery spaces in order to ensure that ventilation, visibility and freedom from smoke are maintained so that, in the event of fire, the

machinery and equipment contained therein may be supervised and continue to function effectively. Alternative and separate means of air supply shall be provided and air inlets of the two sources of supply shall be so disposed that the risk of both inlets drawing in smoke simultaneously is minimized. Such requirements need not apply to control stations situated on, and opening on to, an open deck or where local closing arrangements would be equally effective.

3.10.11 Exhaust ducts shall be provided with hatches for inspection and cleaning. The hatches shall be located near the fire dampers.

3.10.12 Where they pass through accommodation spaces or spaces containing combustible materials, the exhaust ducts from galley ranges shall be constructed of "A" class divisions. Each exhaust duct shall be fitted with:

- a grease trap readily removable for cleaning
- a fire damper located in the lower end of the duct
- arrangements, operable from within the galley, for shutting off the exhaust fans
- fixed means for extinguishing a fire within the duct

3.10.13 The main inlets and outlets of all ventilation systems shall be capable of being closed from outside the spaces being ventilated. The means of closing shall be easily accessible as well as prominently and permanently marked and shall indicate whether the shutoff is open or closed.

3.10.14 Power ventilation of accommodation spaces, service spaces, control stations and machinery spaces shall be capable of being stopped from an easily accessible position outside the space being served. This position shall not be readily cut off in the event of a fire in the spaces served.

3.11 Means of escape

3.11.1 General requirements

3.11.1.1 Unless expressly provided otherwise in this regulation, at least two widely separated and ready means of escape shall be provided from all spaces or group of spaces.

3.11.1.2 Lifts shall not be considered as forming one of the means of escape as required by this regulation.

3.11.2 Means of escape from control stations, accommodation and service spaces

3.11.2.1 Stairways and ladders shall be so arranged as to provide ready means of escape to the lifeboat and liferaft embarkation deck from passenger and crew accommodation spaces and from spaces in

which the crew is normally employed, other than machinery spaces.

3.11.2.2 All stairways in accommodation and service spaces and control stations shall be of steel frame construction except where GL sanctions the use of other equivalent material.

3.11.2.3 Doors in escape routes shall, in general, open in way of the direction of escape, except that:

- individual cabin doors may open into the cabins in order to avoid injury to persons in the corridor when the door is opened
- doors in vertical emergency escape trunks may open out of the trunk in order to permit the trunk to be used both for escape and for access

3.11.2.4 At all levels of accommodation there shall be provided at least two widely separated means of escape from each restricted space or group of spaces.

3.11.2.5 Below the lowest open deck the means of escape shall be stairways, ladders, or watertight doors. At least one of the means of escape, from each watertight compartment or similarly restricted space or group of spaces shall be independent of watertight doors.

3.11.2.6 Above the lowest open deck the means of escape shall be corridors, stairways or doors to an open deck or a combination thereof. There shall be at least two means of escape from each main vertical zone or similarly restricted space or group of spaces.

3.11.2.7 No dead-end corridors having a length of more than 7 m shall be accepted.

3.11.2.8 Stairways and corridors used as means of escape shall be not less than 700 mm in clear width and shall have a handrail on one side. Stairways and corridors with a clear width of 1 800 mm and over shall have handrails on both sides. "Clear width" is considered the distance between the handrail and the bulkhead on the other side or between the handrails. The angle of inclination of stairways should be, in general 45°, but not greater than 50°, in small spaces not more than 60°. Doorways which give access to a stairway shall be of the same size as the stairway.

3.11.2.9 Exceptionally, GL may dispense with one of the means of escape, for crew spaces that are entered only occasionally, if the required escape route is independent of watertight doors.

3.11.3 Means of escape from machinery spaces

3.11.3.1 Except as provided in 3.11.3.2, two means of escape shall be provided from each machinery space of category A. In particular, one of the following provisions shall be complied with:

- Two sets of steel ladders as widely separated as possible leading to doors in the upper part of the space similarly separated and from which

access is provided to the open deck. One of these ladders shall be located within a protected enclosure that satisfies the category (4) requirements of Table 3.1 and 3.2, from the lower part of the space it serves to a safe position outside the space. Self-closing fire doors of the same fire integrity standards shall be fitted in the enclosure. The ladder shall be fixed in such a way that heat is not transferred into the enclosure through non-insulated fixing points. The enclosure shall have minimum internal dimensions of at least 800 mm × 800 mm, and shall have emergency lighting provisions; or

- one steel ladder leading to a door in the upper part of the space from which access is provided to the open deck and, additionally, in the lower part of the space and in a position well separated from the ladder referred to, a steel door capable of being operated from each side and which provides access to a safe escape route from the lower part of the space to the open deck.

3.11.3.2 For a yacht of less than 1 000 gross tonnage, GL may dispense with one of the means of escape required under 3.11.3.1, due regard being paid to the dimension and disposition of the upper part of the space. In addition, the means of escape from machinery spaces of category A need not comply with the requirement for a protected enclosure listed in the first item of 3.11.3.1.

In the steering gear space, a second means of escape shall be provided when the emergency steering position is located in that space unless there is direct access to the open deck.

3.11.3.3 From machinery spaces other than those of category A, two escape routes shall be provided except that a single escape route may be accepted for spaces that are entered only occasionally, and for spaces where the maximum travel distance to the door is 5 m or less.

3.11.3.4 The angle of inclination of stairways in machinery spaces should be not more than 60°.

3.12 Helicopter decks

3.12.1 Structural integrity

3.12.1.1 In general, the construction of the helidecks shall be of steel or other equivalent materials. If the helideck forms the deckhead of a deckhouse or superstructure, it shall be insulated to "A-60" class standard.

3.12.1.2 If GL permits aluminium or other low melting point metal construction that is not made equivalent to steel, the following provisions shall be satisfied:

- If the platform is cantilevered over the side of the ship, after each fire on the ship or on the platform, the platform shall undergo a structural analysis to determine its suitability for further use.
- If the platform is located above the ship's deckhouse or similar structure, the following conditions shall be satisfied:
 - The deckhouse top and bulkheads under the platform shall have no openings.
 - Windows under the platform shall be provided with steel shutters.
 - After each fire on the platform or in close proximity, the platform shall undergo a structural analysis to determine its suitability for further use.

3.12.1.3 Drainage facilities in way of helidecks shall be constructed of steel and shall lead directly overboard independent of any other system and shall be designed so that drainage does not fall onto any part of the ship.

3.12.2 Means of escape

A helideck shall be provided with both a main and an emergency means of escape and access for fire fighting and rescue personnel. These shall be located as far apart from each other as is practicable and preferably on opposite sides of the helideck.

C. Fire Protection and Fire Extinguishing

1. Fire protection measures

1.1 General

1.1.1 To prevent a fire from starting as well as from spreading, preventive measures shall be taken in the area where a fire hazard may exist.

Possible sources of fire are:

- machinery
- electrical installations and appliances
- heating and cooking appliances, etc.

1.1.2 The requirements defined in the following are to be observed in addition to the other relevant parts of these Rules.

1.1.3 Installation of the machinery and the electrical gear in accordance with [Section 1, C.](#) and [D.](#) already provides a certain basic level of required fire protection measures.

1.1.4 All requirements on escape routes and emergency exits are contained in [B.](#)

1.1.5 Compliance with the requirements defined in [C.](#), preventive maintenance of the appliances and installations by the owner and/or the operator of the yacht, plus the latter's prudent behaviour and regular checks will contribute to fire prevention.

1.2 Open flame appliances

1.2.1 General

1.2.1.1 Galley stoves or cookers operating with liquid fuel shall be provided with savealls of non-combustible materials. Measures are to be taken to prevent any leaking fuel to spread through the yacht.

1.2.1.2 Stoves, cookers and heating appliances are to be so installed that undue heating of adjacent structures will not occur.

1.2.1.3 For the operation of galley stoves and cookers using liquid fuels or gas, there shall be adequately sized ventilation openings. If such openings are closable, a notice shall be fitted at the appliance:

"Ventilation openings are to be kept open during the use of stove/cooker!"

1.2.2 Heaters burning liquid fuel

1.2.2.1 Only fuels with a flash point ≥ 55 °C may be used, unless specifically approved otherwise by GL.

1.2.2.2 Only heaters with closed combustion chamber and air supply and exhaust gas lines tight against the interior of the yacht are permitted.

1.2.2.3 Heaters which do not fully meet the requirements regarding safety time margin of a Standard recognized by GL may be approved, if safety of operation is proved in some other way, e.g. by explosion-proof design of the combustion chamber and the exhaust gas ducts.

1.2.3 Liquefied petroleum gas systems

Cooking and heating appliances using liquefied petroleum gas (e.g. propane, butane) shall comply with the following:

- The systems have to be manufactured and installed in accordance with ISO 10239.
- At intervals of not more than 2 years a survey has to be done by an approved expert.

1.2.4 Materials and surfaces in vicinity of open flame cooking appliances

1.2.4.1 Materials and surfaces of components in the vicinity of an open flame cooking appliance must meet the requirements shown in Fig. 3.1. On the right

side the requirements for liquid fuels are defined, on the left side the requirements for gaseous fuels.

Area I: Non-combustible material to be provided

Area II: Approved surface material with low flame spread to be provided

Units: [mm]

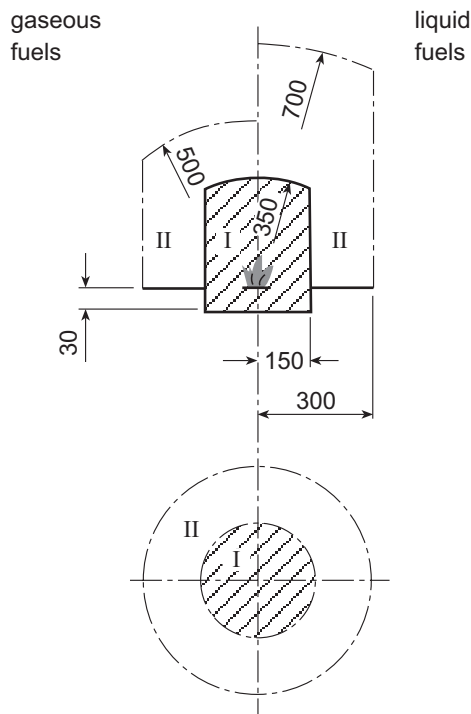

Fig. 3.1 Materials and surfaces of components in the vicinity of an open flame cooking appliance

1.2.4.2 Not readily ignitable materials are to be used for textile draperies.

1.3 Shielding of fuel pipes

Regardless of the intended use and location of any internal combustion engine, all internal fuel injection lines (high pressure lines between injection pumps and injection valves) are to be shielded in such a way that any leaking fuel is:

- safely collected
- drained away unpressurised
- effectively monitored

2. Fire extinguishing arrangements

2.1 General scope of fire extinguishing arrangements

Any yacht is to be equipped with a general water fire extinguishing system and with portable and mobile extinguishers.

2.2 Extinguishing systems

2.2.1 Selection of systems

In addition, depending on their nature, size and the propulsion power installed, spaces subject to a fire hazard are to be provided with fire extinguishing systems according to Table 3.3.

Unless specified otherwise, these systems are normally to be located outside the spaces and areas to be protected and must be capable of being actuated from a readily accessible location not likely to be cut off in the event of a fire in the protected space or area.

2.2.2 General water fire extinguishing systems

Note

Water fire extinguishers are not permitted on yachts flying the German flag.

2.2.2.1 Minimum capacity and number of fire pumps

The minimum capacity and the number of fire pumps shall be as specified in Table 3.4.

2.2.2.2 Emergency fire pumps

On yachts of a length $L > 48$ m an emergency fire pump is to be provided if a fire in any one compartment can put all the fire pumps out of action.

2.2.2.3 Water from two sea chests

For yachts it is sufficient that provision is made for supplying water for fire pumps from one sea chest only.

2.2.2.4 Remote starting arrangement for fire pumps

On yachts of a length $L > 48$ m at least one fire pump is to be provided with remote starting arrangements from the bridge. The associated shut-off valves from the sea water inlet to the fire main must be capable of being controlled from the above mentioned position. Alternatively locally operated valves may be used; these are to be kept open permanently and provided with appropriate signs, e.g.:

"Valve always to be kept open!"

Table 3.3 Fixed fire extinguishing systems

Spaces and areas to be protected	Motor yachts	Sailing yachts
Machinery spaces containing internal combustion engines ¹ or oil fired boilers	CO ₂ system ²	
Paint lockers and flammable liquid lockers	CO ₂ , dry powder extinguishing or pressure water spraying system	
Helicopter landing deck	Low expansion foam	—
¹ installed aggregate power ≥ 375 kW ² alternatively an approved gas fire extinguishing system other than CO ₂ or a pressure water spraying system according to MSC / Circ. 728 will be accepted		

Table 3.4 Minimum number and capacity of fire pumps

Number/capacity of fire pumps	Yachts of a length L ≤ 48 m	Yachts of a length L >48 m
Number of power driven pumps	2	2
Minimum capacity Q of one pump	20 m ³ /h	$Q = 3,8 \cdot 10^{-3} \cdot d_H^2$ ¹ but not less than 25 m ³ /h
¹ d _H [mm] = theoretical diameter of the bilge main according to Section 1, 7.6.1.1		

2.2.2.5 Conditions for emergency fire pumps

The capacity of an emergency fire pump needs not be more than 20 m³/h.

The emergency fire pumps shall fulfil the following conditions:

- installation outside of the space where the main fire pumps are located
- energy supply independent of the space containing the main fire pumps
- self-priming type

2.2.2.6 International shore connection

An international shore connection need not be provided.

2.2.2.7 Arrangement of fire mains

For yachts of a length L > 48 m the GL Rules [Part 1 – Seagoing Ships, Chapter 2 – Machinery Installations, Section 12](#) is to be applied. However, for the shut-off valves at branch pipes for hawspipe flushing local operation will be accepted.

2.2.2.8 Pressure at nozzles

For yachts of a length L ≤ 48 m the system shall be designed for delivering at least one effective jet of water (length of throw approx. 10 m) from any hydrant.

2.2.2.9 Position of hydrants

On yachts of a length L ≤ 48 m hydrants are to be so positioned that any part of the yacht normally accessible can be reached with water from at least one nozzle with not more than 1 standard hose length (for L ≤ 48 m standard hose length on deck: 15 m, in machinery spaces: 10 m; for L > 48 m standard hose length on deck: 20 m, in machinery spaces: 15 m).

2.2.2.10 Hydrants in machinery spaces

For yachts of a length L ≤ 48 m hydrants in machinery spaces need not be provided.

2.2.2.11 Number of hoses and nozzles

For yachts of a length L ≤ 48 m at least 2 hoses and nozzles and for yachts of a length L > 48 m 5 hoses and nozzles have to be provided.

2.2.2.12 Nozzle sizes

The standard nozzle sizes shall be:

- 9 mm or as near thereto as possible for yachts of a length $L \leq 48$ m
- 12 mm or as near thereto as possible for yachts of a length $L > 48$ m

2.2.3 High-pressure CO₂ fire extinguishing systems / rooms for CO₂ cylinders

Accessible CO₂ rooms:

All requirements as defined in the GL Rules [Part 1 – Seagoing Ships, Chapter 2 – Machinery Installations](#)

Non accessible CO₂ rooms:

Such rooms are only suitable for a limited number of cylinders, the arrangement of the cylinders must be suitable for efficient operation. Mechanical ventilation is not required.

2.2.4 Automatic pressure water spraying systems (sprinkler systems)

The system is to meet the GL Rules [Part 1 – Seagoing Ships, Chapter 2 – Machinery Installations](#). However, the capacity of the system need not be higher than that required for the total area to be protected.

2.3 Portable and mobile fire extinguishers

2.3.1 General

2.3.1.1 CO₂ fire extinguishers may not be located in accommodation areas and water fire extinguishers not in machinery spaces.

2.3.1.2 The charge in portable dry powder and gas extinguishers should be at least 5 kg and the content of foam and water extinguishers should be not less than 9 l.

2.3.1.3 A portable foam applicator unit comprises two portable tanks, each containing 20 l of foaming agent, an air-foam jet pipe and ejector unit. The nozzle should be capable of producing at least 1,5 m³/min of foam.

2.3.2 Accommodation

In accommodation decks of yachts portable fire extinguishers are to be arranged not more than 20 m apart at a readily accessible location.

At least one portable fire extinguisher is to be provided on each deck and in each main vertical zone, but the total number shall not be less than:

- 3 for yachts of a length $L \leq 48$ m, or
- 5 for yachts of a length $L > 48$ m

2.3.3 Machinery spaces

2.3.3.1 For yachts of a length $L \leq 48$ m portable dry powder fire extinguishers are to be provided as follows:

- up to 100 kW installed power:
a minimum weight of 6 kg extinguishing agent
- for each further 100 kW or part thereof:
2 kg extinguishing agent in addition

2.3.3.2 For yachts of a length $L > 48$ m the following is to be provided:

- portable dry powder fire extinguishers so located that from any point in the space an extinguisher can be reached within 10 m walking distance
- mobile fire extinguishers of 50 kg dry powder or 45 l foam which shall be so located that any part of the fuel and lubricating oil pressure systems, gearing and other fire hazards can be reached

2.3.4 Other spaces and life boats

Paint lockers, flammable liquid lockers, radio rooms (if any), galleys and motor life boats are each to be equipped with at least one portable fire extinguisher. In motor life boats portable dry powder extinguishers of 2 kg will be accepted.

2.4 Special arrangements for spaces for the carriage of automobiles and other craft

For these spaces the following items have to be provided:

- a pressure water spraying system with a capacity of 5 litres per square meter and minute
- at least 2 dry powder extinguishers of 6 kg each, one extinguisher is to be located at each entrance to the space
- an independent forced ventilation for at least 10 air changes per hour
- electrical equipment with grade of protection IP 55 at least and maximum surface temperature 200 °C

All installations less than 450 mm above a deck shall be approved for use in an explosive petrol/air atmosphere.

D. Closure Conditions, Buoyancy and Stability

1. General

1.1 Classification

Yachts will be assigned Class only after it has been demonstrated that the closure conditions, subdivision,

buoyancy and their intact stability is adequate for the service intended.

1.2 Closure conditions

1.2.1 General

The measures for achieving weathertight integrity shall comply with the International Load Line Convention **LLC 66** as far as reasonable and practicable.

1.2.2 Closure report

A closure plan report in accordance with GL Form F 434 or F 430 for yachts of a length $L > 48$ m, showing all openings, cut-outs, passages, etc. in deck and shell "as built", will be established by the GL Surveyor and sent for approval to the GL Head Office.

1.3 Stability

1.3.1 Adequate intact stability means compliance with standards laid down by the relevant Administration. GL reserve the right to deviate therefrom, if required for special reasons, taking into account the yacht's size and type. The level of intact stability for yachts of all sizes should in any case be not less than that provided by IMO-Resolution A.749(18), excluding Chapter 3 (3.2 weather criterion), unless special operational restrictions reflected in the Class Notation render this impossible.

1.3.2 Evidence of approval by the competent Administration concerned may be accepted for the purpose of Classification.

1.3.3 The above provisions do not affect any intact stability requirements resulting from damage stability calculations, e.g. for yachts which are assigned the symbol \square in the Character of Classification.

1.3.4 Yachts with proven damage stability will be assigned the symbol \square . In the Register book and in an appendix to the Certificate the proof of damage stability will be specified by a five digit code as detailed in the GL Rules [Part 0 – Classification and Surveys, Section 2, C.2.4](#).

1.3.5 The compliance with the requirements of D. is to be checked by calculation and/or trials with the prototype, if any, or with the actual yacht itself in the fully loaded, ready for use condition. Trials are to be carried out under the supervision of a GL Surveyor.

1.4 Documents to be submitted for approval

For the condition of drawings and documents which are necessary for approval see [Section 1, E](#).

1.5 Definitions

1.5.1 Down flooding point

Down flooding point means any opening through which flooding of the spaces which comprise the reserve buoyancy could take place while the yacht is in the intact or damaged condition, and heels to an angle past the angle of equilibrium.

1.5.2 Permeability

The permeability μ of a space is the proportion of the immersed volume of that space which can be occupied by water.

1.5.3 Watertight

Watertight in relation to a structural element means capable of preventing the passage of water through the structure in any direction under the head of water likely to occur in the intact or damaged condition.

1.5.4 Weathertight

Weathertight means that water will not penetrate into the yacht in any wind and wave conditions up to those specified as critical design condition.

1.5.5 Weathertight for heeling

Weathertight for heeling means that all openings liable to become submerged over a certain heeling range shall, if the situation requires, be made weathertight to ensure a stability range up to a certain heeling angle.

Angle of maximum heeling:

- motor yachts: 50°
- sailing yacht, motor sailers: 90°

1.5.6 Angle of heel

φ = angle of heel relative to the y-axis [°], see also [Section 2, Fig. 2.1](#)

1.5.7 Sprayproof

Sprayproof means that no major quantities of water can penetrate into the yacht as a result of short-time immersion.

1.5.8 No unauthorized opening

If openings are accessible during the voyage, they shall be fitted with a device which prevents unauthorized opening.

1.5.9 Positions

The positions for the arrangement of hatches, doors, manholes are:

- Pos. 1: – on exposed freeboard decks
– on raised quarter decks

- on exposed superstructure decks within the forward quarter of **L**
- Pos. 2: – on exposed superstructure decks aft of the forward quarter of **L**

1.6 Anti-heeling devices

1.6.1 If tanks are used as heeling devices, effects of maximum possible tank moments on intact stability are to be checked. A respective proof has to be carried out for several draughts and taking maximum allowable centres of gravity resulting from the stability limit curve as a basis.

1.6.2 If a yacht is equipped with anti-heeling arrangements which may counteract heeling angles of more than 10°, the GL Rules [Part 1 – Seagoing Ships, Chapter 2 – Machinery Installations, Section 11, P.1.4](#) have to be observed.

1.6.3 All devices have to comply with GL Rules [Part 1 – Seagoing Ships, Chapter 3 – Electrical Installations, Section 7, G](#).

2. Openings and closures in hull, deck, cockpit and superstructures

2.1 Decks

2.1.1 Coaming heights for deck openings leading below the freeboard deck, to enclosed superstructures or to spaces considered buoyant in the stability calculation are in general to be in accordance with **LLC 66**, as far as reasonable and practicable.

2.1.2 Where applicable, sill or coaming heights should comply with National Administration requirements.

2.2 Doors and hatches

2.2.1 Doors, hatches and ventilation ducts including their covers, lock tumblers and securing arrangements must be adequately dimensioned. Details are to be submitted for approval.

2.2.2 All doors and escape hatches must be operable from both sides, see also [B](#).

2.3 Ventilation systems

2.3.1 General

2.3.1.1 The thickness of the coaming plates is to be 7,5 mm where the clear opening sectional area of the

ventilator coaming is 300 cm² or less, and 10 mm where the clear opening sectional area exceeds 1 600 cm². Intermediate values are to be determined by direct interpolation. A thickness of 6 mm will generally be considered sufficient within not permanently closed structures.

2.3.1.2 The thickness of ventilator posts should be at least equal to the thickness of coaming as per 2.3.1.1.

2.3.1.3 Generally the coamings and posts shall pass through the deck and shall be welded to the plating from above and below.

2.3.2 Closing appliances

2.3.2.1 Inlet and exhaust openings of ventilation systems are to be provided with easily accessible closing appliances, which can be closed weathertight against wash of the sea. In yachts with the length **L** ≤ 100 m, the closing appliances are to be permanently attached. In yachts with length **L** > 100 m, they may be conveniently stowed near the openings to which they belong.

2.3.2.2 The measures necessary for fire protection are defined in [B](#).

2.4 Hull

2.4.1 Openings in the hull shall comply with SOLAS Regulation II – 1 / 25-10: "External openings in cargo ships".

2.4.2 All openings, cut-outs, passages, etc. in the shell must be designed to be closed by means of suitable devices, fittings, etc., so that no water can enter inside the yacht. This does not apply to cockpit drain pipes, if any.

2.4.3 Regarding inlet and outlet fittings on the shell for the cooling and bilge water as well as sewage lines, see [Section 1, C](#).

2.5 Summary of requirements

The general requirements, which are to be applied as a minimum, are summarized in [Table 3.5](#). The relevant coaming heights are defined in [Table 3.6](#).

Table 3.5 Requirements for openings and closures

Closure components		Requirements	
		Range of service	
		Unrestricted, M, K	W
Shell openings (e.g. windows, shell doors)		Watertight ¹ and no unauthorized opening	
Deck hatches		Weathertight	Sprayproof and weathertight for heeling
Cockpit hatches		Weathertight	Sprayproof and weathertight for heeling
Doors to en-closed spaces and accesses	Pos. 1 and 2	Weathertight	
	all others	Sprayproof	
Ventilation ducts for accommodation		Weathertight	Sprayproof and weathertight for heeling
Ventilation ducts for machinery spaces		Weathertight	
Air pipes		Weathertight	Sprayproof and weathertight for heeling

¹ Weathertight, if situated above the freeboard deck.

Table 3.6 Minimum coaming heights for sailing and motor yachts in [mm]

Closure components	Requirements				
	Position 1	Position 2	No direct access leading below	Normally closed at sea (regardless of position)	Shallow water W
Shell openings (e.g. windows, shell doors)	500 above waterline				50
Deck hatches	600	450	Flush	Flush	50 ²
Cockpit hatches	—	—	—	Flush	Flush
Sliding covers	Only on top of a superstructure or deckhouse within the forward quarter of the yacht's length: 150, behind this point: flush				
Door and accesses to enclosed spaces	600	450	150	50	50
Ventilation ducts for accommodation	900	760	150	—	150
Ventilation ducts for machinery spaces	900	760	760	—	760
	4 500 ¹	2 300 ¹			

¹ height without weathertight covers
² when used at sea. When closed at sea: flush

3. Windows, skylights and side scuttles

3.1 Windows and side scuttles

3.1.1 Closure condition

In any case, windows opening into enclosed spaces shall be watertight and adequately dimensioned for the intended range of service.

Note

The respective ISO-Standards (e.g. DIN ISO 1751 and ISO 3903) are to be considered as guidance. Other types are to be submitted for approval.

3.1.2 Windows in the hull

Windows in the hull which can be opened must be kept closed when at sea. The bottom edge of windows in the hull shall be at least 500 mm above the flotation plane. Windows in the hull are not permitted in machinery spaces.

3.1.3 Deadlights

Deadlights are to be carried on board for all windows in the hull in accordance with the **LLC 66** Regulations as amended or where required from stability point of view.

Windows and side scuttles in deckhouses on the freeboard deck forming the only protection of openings giving access to a space below, are in general to be provided with permanently attached deadlights.

Special constructions with equivalent safety standards may be used on request and after special examination/testing and with the consent of the competent Flag State Administration.

3.1.4 Window panes

Window panes shall preferably be made of toughened, tempered safety glass ("ESG"), or laminated glass ("MSG"); polymethylmethacrylate ("PMMA") and polycarbonate ("PC") sheet material may also be used under special consideration.

Machinery space windows panes in the deckhouses must be of toughened/tempered safety glass, unless an external deadlight is provided, which can be operated in an easy way.

Plastic panes shall be UV-stabilized, in addition scratch resistance is recommended.

3.1.5 Window framing

Panes of PMMA or PC sheet material are to be fixed by frames. They may also be bolted, provided the bolting is capable of resisting the stresses arising and guarantees lasting watertightness. The bearing width of the glass is to be 3 % of whichever is the shortest side of the pane, but at least 20 mm.

Designs offering equivalent safety may be permitted. The strength is to be proven by tests and/or calculation.

Note

If bonding is used, it shall only be executed with materials approved by GL, by personnel certified by GL and considering the requirements of the GL Guideline II – Materials and Welding, Part 2 – Non-metallic Materials, Chapter 3 – Guidelines for Elastomeric Adhesives and Adhesive Joints.

3.1.6 Glass thickness

The window glass thickness has to be determined in accordance with the respective ISO and DIN standards or with equivalent regulations.

3.2 Skylights

3.2.1 All skylights shall be of efficient weather-tight construction and shall be located on or as near to the centreline of the yacht as practicable. If they are of the opening type they shall be provided with efficient means whereby they can be secured in the closed position.

3.2.2 Skylights which are provided as a means of escape shall be operable from both sides. An escape skylight shall be readily identified and easy and safe to use, having due regard to its position and access to and from the skylight.

3.2.3 For glass and framing of skylights see 3.1.4, 3.1.5 and 3.1.6. A minimum of one portable cover for each size of glazed opening should be provided, which can be accessed rapidly and efficiently secured in the event of a breakage of the skylight.

3.2.4 Skylights shall not be fitted in way of the machinery space.

4. Cockpit

Especially for sailing yachts a cockpit may be provided. Its lay-out has to consider the following criteria.

4.1 Structure

The cockpit floor plus longitudinal and transverse walls are to be considered as primary structural members, the scantlings of which shall be in accordance with the requirements of [Section 2](#).

Cockpits shall be watertight to the inside of the yacht.

4.2 Closure condition

Regarding closures and coaming heights of hatches and doors of adjoining storage and living spaces, see [2](#). and [3](#).

4.3 Cockpit floor

The cockpit floor must be sufficiently high above the flotation plane so that water that has entered may be drained immediately through drain pipes or clearing ports under all foreseeable states of heel and trim of the yacht.

4.4 Drain pipes

4.4.1 Cross section

Each cockpit shall be provided with at least one drain pipe at each side. The total cross section f of the pipes on both sides shall be determined as follows:

$$f = 15 \cdot V \quad [\text{cm}^2]$$

V = cockpit volume [m^3], measured to top edge of cockpit coaming at its lowest point

Minimum total cross section for different ranges of service:

- unrestricted: 30,0 cm^2
- **M** and **K**: 20,5 cm^2
- **W**: 15,0 cm^2

These cross section values are also required in the area of any strainers that may be present.

Cockpits extending all the way across the yacht must have clearing ports or drain pipe cross sections in accordance with 6.

4.4.2 Design details

Cockpit drain pipes shall be equal in strength to the surrounding hull and may only be replaced by hoses with special permission of GL. Valves in cockpit drain pipes must be kept permanently open.

4.4.3 Short hose sleeves

Short hose sleeves are permissible under the following conditions:

- The distance between sleeve and waterline shall be at least 100 mm.
- The sleeve shall still be above the waterline with the yacht heeled 15° .
- The hose used shall be in accordance with DIN 10022 or an equivalent standard.
- Two corrosion resistant clips are to be fitted at each end of the sleeve.

5. Deck drainage

5.1 Closure condition

Where bulwarks on exposed portions of freeboard and/or superstructure decks form wells, ample provision is to be made for rapidly freeing the deck of water. Therefore an adequate number of freeing ports or drain pipes of adequate size shall be fitted.

5.2 Freeing ports

5.2.1 The minimum area of openings on one side of the yacht A is to be determined in accordance with the following formula:

$$A = 0,07 \cdot \ell$$

ℓ = length of bulwark [m]

$$\ell_{\max} = 0,7 L$$

5.2.2 The opening area for each well in a superstructure deck shall not be less than 50 % of A .

If the bulwark is more than 1,2 m in average height, A is to be increased by 0,004 m^2 per metre of length of well for each 0,1 m difference in height. If the bulwark is less than 0,9 m in average height, A may be decreased accordingly.

For yachts with no sheer A has to be increased by 50 %. Where the sheer is less than the standard, the percentage shall be obtained by linear interpolation.

5.2.3 Two thirds of the freeing port area required shall be provided in the half of the well nearest to the lowest point of the shear curve.

The lower edges of the freeing ports shall be as near to the deck as practicable.

All openings shall be protected by rails or bars spaced approximately 230 mm apart.

If shutters are fitted, ample clearance shall be provided to prevent jamming.

Hinges shall have pins or bearings of non-corrodible material.

5.3 Scuppers

5.3.1 Scuppers sufficient in number and size to provide effective drainage of water are to be fitted in the weather deck and in the freeboard deck within weathertight closed superstructures and deckhouses. Decks within closed superstructures are to be drained to the bilge. Scuppers from superstructures and deckhouses which are not closed weathertight are to be led outside.

5.3.2 Scupper draining spaces below the design waterline are to be led to the bilges.

Where scupper pipes are led outside from spaces below the freeboard deck and from weathertight closed superstructures and deckhouses, they are to be fitted with screw-down non-return valves (SDNR), which can be closed from a position always accessible and above the freeboard deck. Means showing whether the valves are open or closed are to be provided at the control position.

5.3.3 Scuppers and other discharges should not be fitted in way of life boat launching positions or means for preventing any discharge of water into the life boats are to be provided for. The location of scuppers and other discharges is also to be taken into account when arranging gangways and pilot lifts.

5.4 Drain pipes

Deck drain pipes shall match the surrounding hull in strength.

Valves are not permitted in deck drain pipes.

Deck drain pipes may only be replaced by hoses with special permission of GL.

5.5 Short hose sleeves

The conditions for fitting short hose sleeves defined in 4.4.3. are to be observed.

6. Marking and recording of the design waterline

6.1 General

On application, GL calculate freeboards in accordance with the Regulations of the **LLC 66** ("Load Line Convention 1966") and its 1988 protocol, as

amended, as well as with any existing relevant special national regulation, and subsequently is prepared to issue the necessary Load Line Certificates whenever authorized to do so by the Flag State Administration.

6.2 Load line marks of GL

The maximum draught shall clearly be marked amidships on the yacht's outer sides and shall be recorded in the Safety Certificate or Load Line Certificate, if applicable for the yacht. The ring, lines and letters shall be permanent and be of contrasting colour to the hull of the yacht in way of the mark, see Fig. 3.2.

The waterline corresponding to seawater coincides with the line marked "GL", the waterline for freshwater is marked "F". Further details and the size of the marking are shown in Fig. 3.2.

Exemption from the above may be granted on case by case basis.

6.3 Datum draught marks

Datum draught marks should be provided at the bow and stern, port and starboard and be adequate in number for assessing the condition and trim of the yacht.

The marks should be permanent and easily to be read, but need not be of contrasting colour to the hull. The marks need not be at more than one draught at each position but should be above and within about 1 000 mm of the deepest load waterline.

The draught to which marks relate should be indicated either above the mark on the hull and/or in a record on the general arrangement plan or docking plan, if available.

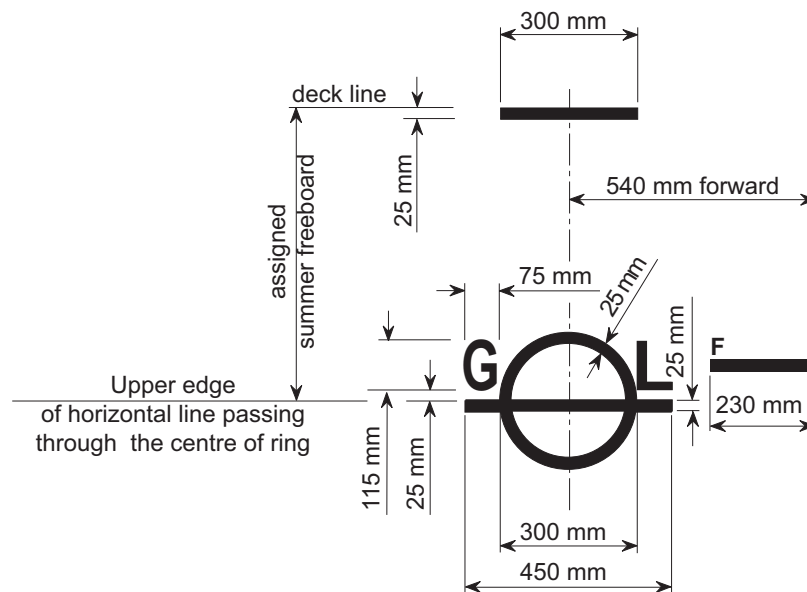

Fig. 3.2 Load line marking for yachts (drawn for starboard side)

7. Intact buoyancy and stability

7.1 Intact buoyancy

7.1.1 All yachts shall have a sufficient reserve of buoyancy at the design waterline to meet the intact stability requirements of 7. This reserve of buoyancy shall be calculated by including only those compartments which are:

- watertight
- accepted as having scantlings and arrangements adequate to maintain their watertight integrity
- situated in locations below a boundary, which may be a watertight deck or an equivalent structure of a non-watertight deck covered by a weathertight structure as defined in 7.1.3

7.1.2 Arrangements shall be provided for checking the watertight integrity of those compartments taken into account in 7.1.1.

7.1.3 Where entry of water into structures above the boundary as defined in 7.1.1, third item would significantly influence the stability and buoyancy of the yacht, such structure shall be:

- of adequate strength to maintain the weathertight integrity and fitted with weathertight closing appliances; or
- provided with adequate drainage arrangements; or
- an equivalent combination of both measures

7.1.4 The means of closing openings in the boundaries of weathertight structures shall be such as to maintain weathertight integrity in all operational conditions.

7.2 Intact stability

7.2.1 Adequate stability of the yacht shall be proven. Insofar as rig, yacht type and propulsive installation do not demonstrate any unusual characteristics, the criteria listed below are used for determining stability.

Legal national regulations beyond these may also have to be complied with.

The yacht shall have its proof of stability based on an inclining experiment; the test is to be supervised by a GL Surveyor.

Note

Compliance with the stability criteria does not ensure immunity against capsizing. Good seamanship is therefore an essential prerequisite for a stability-safe yacht.

7.2.2 Criteria for motor yachts

7.2.2.1 The following criteria have to be fulfilled:

- The area under the righting lever curve (GZ curve) shall not be less than 0,055 metre-radian up to $\phi = 30^\circ$.
- The area under the righting lever curve shall not be less than 0,09 metre-radian up to $\phi = 40^\circ$ or the angle of flooding (angle of heel at which non-weathertight openings immerse).
- Additionally the area under the righting lever curve (GZ curve) between the angles of heel 30° and 40° or between 30° and the angle of flooding, if this angle is less than 40° , shall not be less than 0,03 metre-radian.
- The righting lever GZ should be at least 0,20 m at an angle of heel equal to or greater than 30° .
- The maximum righting arm shall occur at an angle of heel preferably exceeding 30° but not less than 25° .
- The initial metacentric height GM_0 , should be not less than 0,35 m.
- The turning circle angle of heel is to be determined by trials and shall not exceed 12° at maximum speed. During trials the speed is to be increased in steps. If the turning circle angle of heel exceeds 12° before maximum speed is attained the test has been failed.

If any of these criteria are not complied with, this may be accepted by GL if proof of equivalent safety is provided.

7.2.2.2 The proof of adequate stability shall be provided for at least the following conditions:

- yacht in the fully loaded departure condition, with full stores and fuel and with the full number of crew and guests with their luggage
- yacht in the fully loaded arrival condition, with the full number of crew and guests with their luggage, but with only residual stores and fuel remaining

7.2.2.3 GL reserve the right to deviate from the above regulations when particular circumstances warrant this.

7.2.3 Criteria for sailing yachts

7.2.3.1 The following criteria have to be fulfilled:

- The areas B + C shall be not less than 1,4 (A + B), see Fig. 3.3.
- The righting lever at the maximum of the lever arm curve shall be not less than 0,30 m.
- The stability range shall be not less than 60° for yachts without ballast keel.

- The stability range shall be not less than 90° for yachts with ballast keel.
- The initial metacentric height GM_0 shall not be less than 0,60 m.
- The static angle of heel under sail shall not exceed 20° , but in any way shall not be more than the angle of deck immersion.

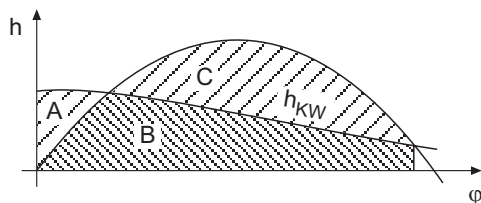

Fig. 3.3 Lever arm curve

h_{KW} = curve of heeling levers due to lateral wind pressure

7.2.3.2 If any of these criteria are not complied with, this may be accepted by GL, if proof of equivalent safety is provided.

For multi hull sailing craft, stability ranges smaller than 60° may be permitted.

7.2.3.3 The proof of adequate stability shall be provided for the yacht at least under the following conditions:

- all sails set
- half the sail area
- storm sails
- sails struck

In each case the permissible wind speed or force shall be determined at which the limit of stability set by the criteria is reached. With the sails struck, a lateral wind pressure equivalent to Beaufort-Force 12 ($32,7 - 36,9 \text{ m/s} = 63,6 - 71,7 \text{ kn}$) must be tolerable.

7.2.4 Ice Class

The effect of icing has to be considered in the stability calculation if a Class Notation for ice has been requested.

8. Subdivision and damage stability

8.1 Bulkheads

8.1.1 At least the following watertight bulkheads are to be fitted in all yachts:

- one collision bulkhead
- one afterpeak bulkhead
- one bulkhead at each end of the machinery space

8.1.2 The distance [m] of the collision bulkhead from the forward perpendicular is to be between $0,035 L$ and $0,05 L + 3 \text{ m}$.

8.1.3 Where compliance with 8.1.2 seems impractical for the particular design of the yacht, the requirement may be substituted by proof of survivability of simultaneous damage to all compartments between $0,035 L$ and the forward end of the yacht according to the criteria defined in 8.3.3.

8.2 Double bottom

8.2.1 At least for yachts with a length L exceeding 48 m a double bottom should be fitted extending from the fore peak bulkhead to the after peak bulkhead, as far as practicable and compatible with the design and proper operation of the ship. In any case, a double bottom must be fitted in areas prescribed in Regulation II-1/12 of SOLAS 74.

8.2.2 The double bottom has to protect the yacht's bottom up to the turn of the bilge. For this purpose, the intersecting line of the outer edge of the margin plate with the shell plating is not to be lower at any part than a horizontal plane, passing through the point of intersection with the frame line amidships of a transverse diagonal line inclined 25 degrees to the baseline and cutting the base line at $B/2$ from the centreline of the yacht (see Fig. 3.4).

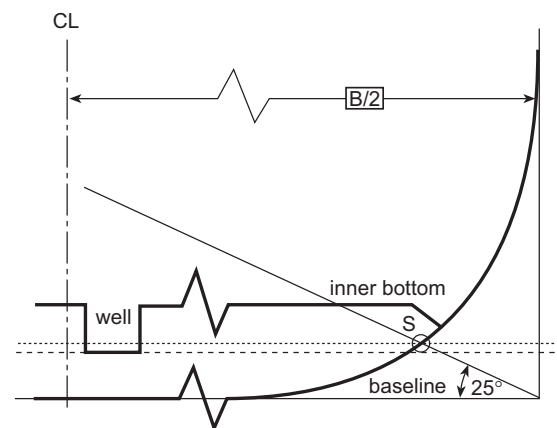

..... minimum height of inner bottom (measured from baseline)
---- 460 mm (measured from baseline)

Fig. 3.4 Double bottom with drain sumps location

8.2.3 The double bottom need not be fitted in way of deep tanks, provided that the efficiency of the watertight subdivision is not impaired by such an arrangement.

8.2.4 The bottoms of drain sumps are to be situated at a distance of at least 460 mm from the base line. Only above the horizontal plane determined from 8.2.2, the bottoms of drain wells may be led to the shell plating. Exemptions for the depth of drain

wells may also be granted in shaft tunnels and pipe tunnels.

8.3 Damage stability

8.3.1 General

For yachts with a length **L** exceeding 48 m a damage stability investigation is required.

For yachts with a length **L** between 48 m and 85 m sufficient damage stability has to be shown by calculating one compartment damages. For yachts with a length **L** exceeding 85 m a calculation of two compartment damages is required additionally.

8.3.2 Damage stability calculation

8.3.2.1 General

Compliance with the damage stability criteria has to be shown in all permitted conditions of loading to withstand all stages of flooding of the main compartments.

8.3.2.2 Assumptions

The damage stability calculation shall be based on the following assumptions:

- The assumed extent of damage shall be as follows:
 - longitudinal extent: 3 m plus 3 % of the length **L** of the yacht or 11 m, whichever is less
 - transverse extent (to be measured inboard from the ship's side, at right angles to the centre line at the level of the deepest subdivision load line): a distance of one fifth of the breadth of the yacht
 - vertical extent: from the base line upwards without limit
 - If any damage of lesser extent than that indicated above would result in a more severe condition regarding heel or loss of metacentric height, such damage shall be assumed in the calculations.
- For damage stability calculations, the permeability for each space or part of a space shall be used as set out in Table 3.7.
- Direct calculation of permeability shall be used where a more onerous condition results, and may be used where a less onerous condition results, if compared with the second item.

Table 3.7 Values of permeability

Definition of spaces	Permeability [%]
Control stations, accommodation rooms, kitchens, pantries	95
Machinery and ventilation rooms	85
Storage rooms, refrigerating rooms	60
Garages for automobiles and other craft	90
Tanks, bunkers, cells	0 or 95 ¹
Void spaces	95
¹ whichever results in more severe requirements	

8.3.3 Stability criteria

8.3.3.1 The stability required in the final condition after damage, and after equalization where provided, shall be determined as follows:

- The positive residual righting lever curve shall have a minimum range of 15° beyond the angle of equilibrium.
- The area under the righting lever curve shall be at least 0,015 metre-radians, measured from the angle of equilibrium to the angle at which progressive flooding occurs.
- A residual righting lever is to be obtained within the range of the positive stability of at least 0,1 m.

8.3.3.2 Unsymmetrical flooding has to be kept to a minimum. Efficient cross flooding arrangements should correct large angles of heel preferably in a self acting way. If the cross flooding system is not self-acting the required time of equalization shall not exceed 15 minutes. Sufficient time of equalization has to be demonstrated by calculation.

8.3.4 Final condition of yacht

The final conditions of the yacht after damage and, in case of unsymmetrical flooding, after equalization measures have been taken, shall be as follows:

- In case of symmetrical flooding there shall be a positive residual metacentric height of at least 50 mm as calculated by the constant displacement method.
- In case of unsymmetrical flooding, the angle of heel for one-compartment flooding shall not exceed 7°, for the simultaneous flooding of two or more adjacent compartments, a heel of 12° may be permitted by GL.

- In no case shall the final waterline be less than 300 mm below the level of any opening through which further flooding could take place.

8.3.5 Use of low density foam

Use of low density foam or other media to provide buoyancy in void spaces may be permitted, provided that satisfactory evidence is provided that any such proposed medium is the most suitable alternative and is:

- of closed cell form, or otherwise impervious to water absorption
- structurally stable under service conditions
- chemically inert in relation to structural materials with which it is in contact or to other substances with which the medium is likely to be in contact
- properly secured in place and easily removable for inspection of the void spaces

8.4 Damage control plan

8.4.1 There shall be permanently exhibited or readily available on the navigating bridge, for the guidance of the officer in charge of the yacht, a plan showing clearly:

- for each deck and compartment the boundaries of the watertight compartments, the openings therein with the means of closure and position of any controls thereof
- for doors, a description of degree of tightness, operating mode, normal position, operating circumstances (opened while at sea, not normally used while at sea, not used while at sea)
- arrangements for the correction of any list due to flooding

8.4.2 General precautions shall consist of a listing of equipment, conditions and operational procedures, considered to be necessary to maintain watertight integrity under normal yacht operations.

8.4.3 Specific precautions shall consist of a listing of elements (i.e. closures, securing of equipment/loads, sounding of alarm, etc.) considered to be vital to the survival of the yacht and its crew.

9. Inclining and stability information

9.1 Every yacht on completion of build shall undergo an inclination test and the elements of its stability determined. If an accurate inclining is not practical, the lightship displacement and centre of gravity should be determined by a lightweight survey and accurate calculation.

9.2 The master shall be supplied by the owner with reliable information relating to the stability of the yacht in accordance with the provisions of D. The information relating to stability shall, before issue to the master, be submitted to GL for approval and shall incorporate such additions and amendments as GL may require in any particular case.

9.3 Where any alterations are made to a yacht so as to materially affect the stability information supplied to the master, amended stability information should be provided. If necessary, the yacht shall be re-inclined.

9.4 A report of each inclination test carried out in accordance with D. or of each calculation of the lightship condition particulars shall be submitted to GL for approval. The approved report shall be placed on board of the yacht in the custody of the master/owner and should incorporate such additions and amendments as GL may require in any particular case.

E. Requirements for Hydraulically-Operated Equipment

1. General

1.1 Scope

The requirements contained in E. apply to hydraulically-operated systems used, for example, to move deck/hatch covers, closing appliances in the yacht's shell and at bulkheads, hoists and stabilizers. The requirements are to be applied in analogous manner to the yacht's other hydraulic systems.

1.2 Documents for approval

The diagram of the hydraulic system together with drawings of the cylinders containing all the data necessary for assessing and checking the system, e.g. operating data, descriptions, materials used, etc. are to be submitted in triplicate for approval.

1.3 Dimensional design

For the design of pressure vessels and for dimensions of pipes and hose assemblies see references defined in [Section 1, C](#).

1.4 Materials

1.4.1 Approved materials

1.4.1.1 Components fulfilling a major function in the power transmission system shall normally be made of steel or cast steel in accordance with the GL Rules II – Materials and Welding, Part 1 – Metallic

Materials. The use of other materials is subject to special agreement with GL.

Cylinders are preferably to be made of steel, cast steel or nodular cast iron (with a predominantly ferritic matrix).

1.4.1.2 Pipes are to be made of seamless or longitudinal welded steel tubes.

1.4.1.3 The pressure-loaded walls of valves, fittings, pumps, motors, etc. are subject to the requirements of the references defined in [Section 1, C](#).

1.4.2 Testing of materials

The following components are to be tested under supervision of GL in accordance with the GL Rules II – Materials and Welding, Part 1 – Metallic Materials:

- pressure pipes with nominal diameter $D_N > 32$
- cylinders, where the product of the pressure times the diameter is:

$$p \cdot D_i > 20\,000$$

p = maximum allowable working pressure [bar]

D_i = inside diameter of tube [mm]

- hydraulic accumulators

Testing of materials may be dispensed with in case of cylinders for secondary applications, provided that evidence in the form of a works test certificate (e.g. EN 10204-2.3) is supplied.

2. Covers for deck openings

2.1 Scope

The following requirements apply to hydraulic power equipment for opening and closing of covers for deck openings and hatches.

2.2 Design and construction

2.2.1 Hydraulic operating equipment for deck openings and hatch covers may be served either by one common power station for all openings or several power stations individually assigned to a single cover. Where a common power station is used, at least two pump units are to be fitted. Where the systems are supplied individually, change-over valves or fittings are required so that operation can be maintained should one pump unit fail.

2.2.2 Movement of the covers may not be initiated by the starting of the pumps. Special control stations are to be provided for controlling the opening and the closing of the covers. The controls are to be so designed, that as soon as they are released, movement of the cover stops immediately.

The openings/hatches should normally be visible from the control station. Should this, in exceptional cases, be impossible, opening and closing of the covers is to be signalled by an audible alarm. In addition, the control station must then be equipped with indicators for monitoring the movement of the covers.

2.2.3 Suitable equipment must be fitted in, or immediately adjacent to, each power unit (cylinder or similar) used to operate covers to enable the openings to be closed slowly in the event of a power failure, e.g. due to pipe rupture.

2.3 Pipes

2.3.1 Pipes are to be installed and secured in such a way as to protect them from damage while enabling them to be properly maintained from outside.

Pipes may be led through tanks in pipe tunnels only. The piping system is to be fitted with relief valves to limit the pressure to the maximum allowable working pressure.

2.3.2 The piping system is to be fitted with filters for cleaning the hydraulic fluid.

Equipment is to be provided to enable the hydraulic system to be vented.

2.3.3 The accumulator space of the hydraulic accumulator must have permanent access to the relief valve of the connected system. The gas chamber of the accumulator may be filled only with inert gases. Gas and operating medium are to be separated by accumulator bags, diaphragms or similar.

2.3.4 Connection between the hydraulic system used for operation of covers for deck openings and other hydraulic systems is permitted only with the consent of GL.

2.3.5 Tanks forming part of the hydraulic system are to be fitted with oil level indicators.

2.3.6 The hydraulic fluids must be suitable for the intended ambient and service temperatures.

2.4 Hose assemblies

The construction of hose assemblies shall conform to the references given in [Section 1, C](#). The requirement that hose assemblies should be of flame-resistant construction may be set aside for hose lines in spaces not subject to a fire hazard and in systems not important to the safety of the ship.

2.5 Emergency operations

It is recommended that devices be fitted which are independent of the main system and which enable the covers to be opened and closed in the event of failure

of the main system. Such devices may, for example, take the form of loose rings enabling covers to be moved by warping winches, etc.

3. Closing appliances in the yacht's shell

3.1 Scope

The following requirements apply to power equipment of hydraulically operated closing appliances in the yacht's shell such as shell doors and platforms at the yacht's side and stern.

3.2 Design and construction

3.2.1 The movement of the shell doors, etc. may not be initiated merely by starting of the pumps at the power station.

3.2.2 Local control, inaccessible to unauthorized persons, is to be provided for every closing appliance in the yacht's shell. As soon as the controls (pushbuttons, levers or similar) are released, movement of the appliance must stop immediately.

3.2.3 Closing appliances in the yacht's shell should normally be visible from the control station. If the movement cannot be observed, audible alarms are to be fitted. In addition, the control station is then to be equipped with indicators enabling the execution of the movement to be monitored.

3.2.4 Closing appliances in the yacht's shell are to be fitted with devices which prevent them from moving into their end positions at excessive speed. Such devices are not to cause the power unit to be switched off.

As far as is required, mechanical means must be provided for locking closing appliances in the open position.

3.2.5 Every power unit driving horizontally hinged or vertically operated closing appliances is to be fitted with throttle valves or similar devices to prevent sudden dropping of the closing appliance.

3.2.6 It is recommended that the driving power be shared between at least two mutually independent pump sets.

3.3 Pipes, hose assemblies

2.3 and 2.4 are to be applied in analogous manner to the pipes and hose lines of hydraulically operated appliances in the yacht's shell.

4. Bulkhead closures

4.1 Scope

4.1.1 The following requirements apply to the power equipment of hydraulically-operated watertight bulkhead doors.

4.1.2 For the arrangement of bulkheads see [D.8](#).

4.2 Design

Bulkhead doors shall be power-driven sliding doors moving horizontally. Other designs require the approval of GL and the provision of additional safety measures where necessary.

4.3 Piping

4.3.1 Where applicable, the pipes in hydraulic bulkhead closing systems are governed by the Rules in 2.3, with the restriction that the use of flexible hoses is not permitted.

4.3.2 The hydraulic fluids must be suitable for the intended ambient and service temperatures.

4.4 Drive unit

4.4.1 A selector switch with the switch positions "local control" and "close all doors" is to be provided at the central control station on the bridge.

Under normal conditions this switch should be set to "local control". In this position, the doors may be locally opened and closed without automatic closure.

In the "close all doors" position, all doors are closed automatically. They may be reopened by means of the local control device but must close again automatically as soon as the local door controls are released. It shall not be possible to open closed doors from the bridge.

4.4.2 Closed or open bulkhead doors shall not be set in motion automatically in the event of a power failure.

4.4.3 The control system is to be designed in such a way that an individual fault inside the control system, including the piping, does not have any adverse effect on the operation of the bulkhead doors.

4.4.4 The controls for the power drive are to be located at least 1,6 m above the floor on both sides of the bulkhead close to the doors. The controls are to be installed in such a way that a person passing through the door is able to hold both controls in the open condition.

The controls must return to their original position automatically when released.

4.4.5 The direction of movement of the controls is to be clearly marked and must be the same as the direction of the movement of the door.

4.4.6 In the event that an individual element fails inside the control system for the power drive, including the piping, but excluding the closing cylinders on the door or similar components, the operational ability of the manually-operated control system must not be impaired.

4.4.7 The movement of the power driven bulkhead doors may not be initiated simply by switching on the drive units but only by actuating additional devices.

4.4.8 The control and monitoring equipment for the drive units is to be housed in the central control station on the bridge.

4.5 Manual control

4.5.1 Each door must have a manual control system which is independent of the power drive.

4.5.2 The manual control must be capable of being operated at the door from both sides of the bulkhead.

4.5.3 The controls must allow the door to be opened and closed.

4.6 Indicators

Visual indicators to show whether each bulkhead door is fully open or closed are to be installed at the central control station on the bridge.

4.7 Electrical equipment

For electrical equipment see [Section 1, D](#).

4.8 Alarms

Whilst all doors are being closed from the central control station, an audible alarm must be sounded.

5. Hoists

5.1 Scope

For the purpose of these requirements, hoists include hydraulically-operated appliances such as lifts and similar equipment.

5.2 Design and construction

5.2.1 Hoists may be supplied either by a combined power station or individually by several power stations.

In case of a combined power supply and of hydraulic drives whose piping system is connected to other hydraulic systems, a second pump unit is to be fitted.

5.2.2 The movement of hoists shall not be capable of being initiated merely by starting the pumps. The movement of the hoists is to be controlled from a special operating station. The controls are to be so arranged that, as soon as they are released, the movement of the hoist ceases immediately.

5.2.3 Local controls, inaccessible to unauthorized persons, are to be fitted. The movement of hoists should normally be visible from the operating station. If the movement cannot be observed, audible and/or visual warning devices are to be fitted. In addition, the operating station is then to be equipped with indicators for monitoring the movement of the hoist.

5.2.4 Devices are to be fitted which prevent the hoist from reaching its end position at excessive speed. The devices are not to cause the power unit to be switched off. As far as necessary, mechanical means must be provided for locking the hoist in its end position.

If the locking devices cannot be observed from the operating station, a visual indicator is to be installed at the operating station to show the locking status.

5.2.5 [2.2.3](#) is to be applied in analogous manner to those devices which, if the power unit fails or a pipe ruptures, ensure that the hoist is slowly lowered.

5.3 Pipes, hose assemblies

[2.3](#) and [2.4](#) apply in analogous manner to the pipes and hose lines of hydraulically operated hoists.

6. Stabilizers

6.1 Scope

The following requirements apply to stabilizer drive units suitable for reducing the roll movement and for securing the safety of the ship.

6.2 Design and construction

6.2.1 Pipes of the hydraulic system are to be made of seamless or longitudinally welded steel tubes.

The use of cold drawn, unannealed tubes is not permitted.

At points where they are exposed to danger, copper pipes for control lines are to be provided with protective shielding and are safeguarded against hardening due to vibration by use of suitable fastenings.

6.2.2 High pressure hose assemblies may be used for short pipe connections subject to compliance with the references of [Section 1, C](#). if this is necessary due to vibrations or flexible mounting units.

6.2.3 The materials used for pressurized components including the seals must be suitable for the hydraulic oil in use.

6.2.4 The sealing arrangement at the penetration of the fin shaft through the yacht's shell has to be submitted for approval.

6.2.5 For retractable stabilizer fins the actual position has to be indicated at the bridge.

7. Tests and trials

7.1 Tests in the manufacturer's factory

7.1.1 Testing of power units

The power units are required to undergo testing on a test bed. Factory test certificates for this testing are to be presented at the final inspection of the hydraulic system.

7.1.2 Pressure and tightness tests

Pressure components are to undergo a pressure test.

The test pressure

$$p_c = 1,5 \cdot p \text{ [bar]}$$

p = the maximum allowable working pressure [bar] or the pressure at which the relieve valves open. However, for working pressures above 200 bar the test pressure need not exceed $p + 100$ bar.

For pressure testing of pipes their valves and fittings, see references in [Section 1, C](#).

Tightness tests are to be performed on components to which this is appropriate at the discretion of the GL Surveyor.

7.2 Shipboard trials

7.2.1 After installation on board, the equipment is to undergo an operational test.

7.2.2 The operational test of watertight doors has to include the emergency operating system and determination of closing time.

7.2.3 The operational efficiency of the stabilizer equipment is to be demonstrated during the sea trials.

F. Requirements for Helicopter Facilities

1. General

1.1 Scope

1.1.1 The following describes the requirements for the arrangement and the structures of helicopter landing deck, the arrangement of aviation fuel tanks and the necessary safety measures including fire extinguishing.

1.1.2 It is assumed that only one helicopter will be operated at a time. The landing deck is to be dimensioned for the largest helicopter type expected for helicopter operation. The characteristics of this helicopter type have to be defined clearly in the documents submitted for approval. It is assumed that the helicopter is parking on the open landing deck being safely lashed to the deck.

1.2 Hangar

If a helicopter hangar is provided, the additional requirements have to be defined case by case on the basis of other GL Rules.

1.3 Operation manual

Each helicopter facility shall have an operation manual, including a description and a checklist of safety precautions, procedures and equipment requirements.

2. Arrangement of helicopter landing decks

2.1 Positioning of the landing deck

A helicopter landing deck shall be situated on an upper deck. If the helicopter deck is situated at the stern of the yacht with superstructures/deckhouses beforehand it is recommended that the angle of possible approaches should be at least 90° at each side of the yacht's longitudinal axis.

A location of permanently occupied spaces, like accommodation, messes, service spaces under the helicopter deck shall be avoided because of safety reasons. If this is not possible, then the landing deck has to be designed completely as a crash zone, see 3.2, load case LC 3.

2.2 Size of a landing deck

In establishing a landing area it is essential to ensure a safe correlation between:

- the sizes of helicopters expected to use the landing deck
- the dimensions of the aiming circle, clear zone and manoeuvring zone and the permitted height of obstructions in these zones, see Fig. 3.5

The following three zones can be defined for a landing area:

– Aiming circle/touch down zone:

The aiming circle is an area concentric to the centre of the clear zone and has a diameter half that of the clear zone itself. The circle shall accommodate with safety the landing gear of helicopters for which it is intended and shall therefore be completely obstruction free. If this is not possible, obstructions not higher than 0,1 m may be permissible.

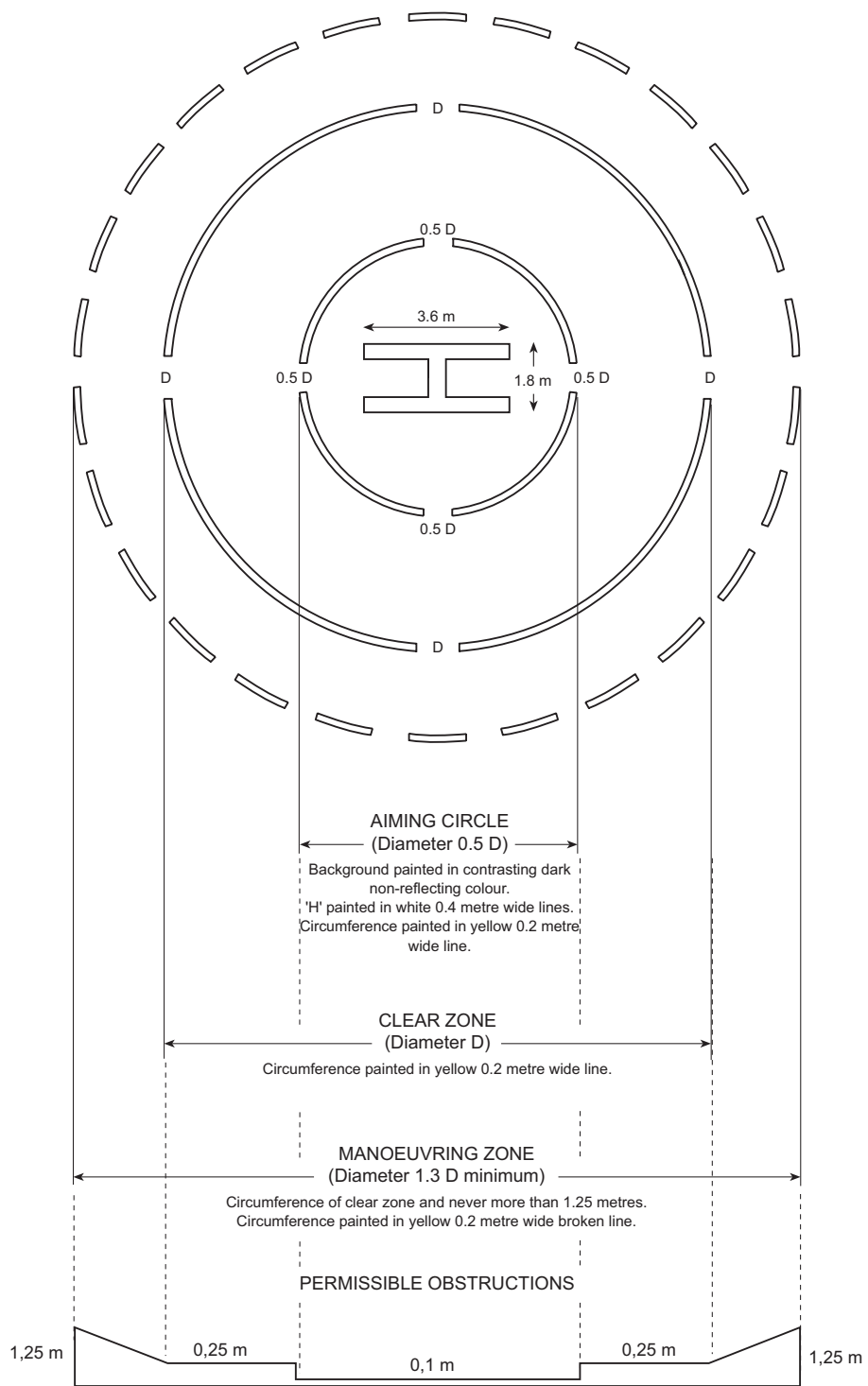

N.B. D, the diameter (in metres) of the clear zone, must be greater than the overall length, with rotors turning, of a helicopter which may use the area.

Fig. 3.5 Definition of a helicopter landing area

– **Clear zone:**

The clear zone shall be as large as possible recognising that its diameter D must be greater than the overall length with rotors turning, of a helicopter planned to use the landing area. There shall be no obstacles in the clear zone higher than 0,25 m.

– **Manoeuvring zone:**

The manoeuvring zone of the landing area extends the area in which the helicopter may manoeuvre with safety by enlarging, to a diameter of at least 1,3 D, the area over which the rotors of the helicopter may overhang without danger from high obstructions. If it is impossible to remove all obstacles from the manoeuvring zone, a graduated increase in permitted height of obstructions is defined in Fig. 3.5.

Note

For the convenience of the users of these Rules reference is made to the "Guide to Helicopter/Ship Operations" published by the International Chamber of Shipping (ICS).

3. Landing deck structures

3.1 Design loads

The following design load cases (LC) are to be considered:

3.1.1 LC 1

helicopter lashed on deck, with the following vertical forces acting simultaneously:

- wheel and/or skid force P acting at the points resulting from the lashing position and distribution of the wheels and/or supports according to helicopter construction.

$$P = 0,5 \cdot G (1 + a_v) \text{ [kN]}$$

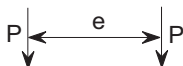

G = maximum permissible take-off weight [kN]

P = evenly distributed force over the contact area $f = 30 \times 30$ cm for single wheel or according to data supplied by helicopter manufacturers; for dual wheels or skids to be determined individually in accordance with given dimensions.

e = wheel or skid distance according to helicopter types to be expected

$$a_v = F \cdot m$$

$$F = 0,11 \frac{v_0}{\sqrt{L}}$$

$$m = m_0 - 5 \left(m_0 - 1 \right) \frac{x}{L}$$

$$\text{for } 0 \leq \frac{x}{L} \leq 0,2$$

$$= 1 \text{ for } 0,2 \leq \frac{x}{L} \leq 0,7$$

$$= 1 + \frac{m_0 + 1}{0,3} \left(\frac{x}{L} - 0,7 \right)$$

$$\text{for } 0,7 < \frac{x}{L} \leq 1,0$$

$$m_0 = 1,5 + F$$

$$v_0 = \text{see Section 2, A.6.5}$$

- force due to weight of helicopter deck M_e as follows:

$$M_e (1 + a_v) \text{ [kN]}$$

- load $p = 2,0$ kN/m² evenly distributed over the entire landing deck

3.1.2 LC 2

helicopter lashed on deck, with the following horizontal and vertical forces acting simultaneously:

- forces acting horizontally:

$$H = 0,6 (G + M_e) + W \text{ [kN]}$$

W = wind load, taking into account the lashed helicopter;

$$\text{wind velocity } v_w = 50 \text{ m/s}$$

- forces acting vertically:

$$V = G + M_e \text{ [kN]}$$

3.1.3 LC 3

normal landing impact, with the following forces acting simultaneously:

- wheel and/or skid load P at two points simultaneously, at an arbitrary (most unfavourable) point of the helicopter deck (landing zone + safety zone)

$$P = 0,75 G \text{ [kN]}$$

- load $p = 0,5$ kN/m² evenly distributed (for taking into account snow or other environmental loads)

- weight of the helicopter deck

- wind load in accordance with the wind velocity admitted for helicopter operation (v_w). Where no data are available, $v_w = 25$ m/s may be used.

3.2 Scantlings of structural members

3.2.1 Stresses and forces in the supporting structure are to be evaluated by means of direct calculations.

3.2.2 Permissible stresses for stiffeners, girders and substructure:

$$\sigma_{zul} = \frac{235}{k \cdot \gamma_f} \left[\text{N/mm}^2 \right]$$

γ_f = safety factor according to Table 3.8.

Table 3.8 Safety factors for heli deck structures

Structural element	γ_f	
	LC 1 LC 2	LC 3
stiffeners (deck beams)	1,25	1,1
main girders (deck girders)	1,45	1,45
load-bearing structure (pillar system)	1,7	2,0

3.2.3 The thickness of plating is to be determined according to

$$t = c \cdot \sqrt{p \cdot k} + t_K \quad [\text{mm}]$$

k = material factor, see Section 2, B.

t_K = corrosion allowance, see Section 2, G.2.2.2

c = factor to be determined as follows:

- for the aspect ratio $\frac{b}{a} = 1$ and for the

range $0 < \frac{f}{F} \leq 0,3$ (refer to Fig. 3.6):

$$c = 1,87 - \sqrt{\frac{f}{F} \left(3,4 - 4,4 \frac{f}{F} \right)}$$

- for the aspect ratio $\frac{b}{a} = 1$ and for the

range $0,3 \leq \frac{f}{F} \leq 1,0$:

$$c = 1,2 - 0,4 \frac{f}{F}$$

- for the aspect ratio $\frac{b}{a} \geq 2,5$ and for the range $0 < \frac{f}{F} < 0,3$:

$$c = 2,0 - \sqrt{\frac{f}{F} \left(5,2 - 7,2 \frac{f}{F} \right)}$$

- for the aspect ratio $\frac{b}{a} \geq 2,5$ and for the

range $0,3 \leq \frac{f}{F} \leq 1,0$:

$$c = 1,2 - 0,517 \frac{f}{F}$$

For intermediate values of b/a the factor c is to be obtained by direct interpolation.

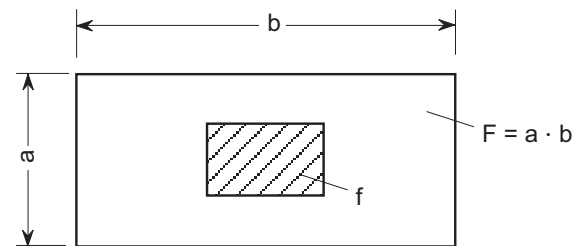

Fig. 3.6 Print area of wheel within plate panel

3.3 Materials

3.3.1 Helicopter landing decks shall be of steel or steel equivalent fire-resistant construction. If the space below the helicopter landing deck is a high fire risk space, adequate insulation has to be provided, see B.

3.3.2 If aluminium or other low melting metal construction that is not made equivalent to steel are permitted, the following provisions for helicopter decks above a deckhouse or similar structure shall be satisfied:

- The deckhouse top and the bulkheads under the platform shall have no openings.
- All windows under the platform shall be provided with steel shutters.
- The required fire fighting equipment shall be provided according to 5. and be to satisfaction of the Administration.
- After each fire on the deck or in close proximity, the helicopter landing deck shall undergo a structural analysis to determine its suitability for further use.

4. Landing deck equipment

4.1 Landing deck sheathing

The landing deck sheathing has to comply with the following requirements:

- resistant against increased mechanical impact at starting and landing procedure
- resistant against aircraft fuel, hydraulic and lubricating oils
- resistant against dry fire extinguishing powder and foams
- resistant against defrosting expedient and salt
- friction coefficient $\mu = 0,6$ at minimum

4.2 Helicopter fastenings

In the parking zone means have to be provided for lashing of the helicopter. It is recommended to provide one lashing point for about 2 m² of the landing deck. The lashing points have to be flush with the deck.

4.3 Personnel safety measures

4.3.1 Two means of escape have to be provided from the landing deck. They shall be situated at the maximum possible distance from each other.

4.3.2 A collapsible railing has to be provided at the perimeter of the landing deck.

The railing shall follow the requirements for guard-rails according to A.2. The design shall be based on an outreach of 1,5 m at the folded down position, a mesh size of about 80 mm and a design load of at least 2,0 kN/m².

5. Fire extinguishing systems

5.1 In close proximity to the helicopter landing deck there shall be provided and stored near the means of access to that deck:

5.1.1 At least two dry powder extinguishers having a total capacity of not less than 45 kg;

5.1.2 CO₂-extinguishers of a total capacity of not less than 18 kg or equivalent;

5.1.3 A fixed low expansion foam system with monitors or foam making branch pipes capable of delivering foam to all parts of the helideck in all weather conditions in which helicopters can operate. The system shall be capable of delivering a discharge rate as required in Table 3.9 for at least five minutes.

Table 3.9 Discharge rate of foam solution

Helicopter category	Overall length of helicopter l [m]	Discharge rate of foam solution [l/min]
H1	$l < 15$	250
H2	$15 \leq l < 24$	500

The foam agent shall meet the performance standards of ICAO 24 and be suitable for use with salt water.

5.1.4 At least two nozzles of dual-purpose type and hoses sufficient to reach any part of the helideck.

5.1.5 Two firemen's outfits in addition to those required by SOLAS or national regulations.

5.1.6 At least the following equipment, stored in a manner that provides for immediate use and protection from the elements:

- adjustable wrench
- blanket, fire resistant
- cutters bolt 600 mm
- hook, grab or salvaging
- hacksaw, heavy duty complete with 6 spare blades
- ladder
- life line 5 mm diameter × 15 m in length
- pliers, side cutting
- set of assorted screwdrivers
- harness knife complete with sheath

5.2 Drainage of the helicopter landing deck

Drainage facilities in way of helicopter landing decks shall be constructed of flame proof material/steel and lead directly overboard independent of any other system and designed so that drainage does not fall on to any part of the yacht.

6. Aviation fuel arrangement

6.1 General

The following requirements apply to aviation fuel with a flash point above or below 60 °C.

6.2 Storage

6.2.1 General

6.2.1.1 For the storage of aviation fuel the general safety measures for fuel tanks are to be applied analogously, see Section 1, C.

6.2.1.2 The aviation fuel has to be stored in dedicated tank(s).

6.2.2 Arrangement of tanks

The arrangement of aviation fuel tanks has to comply with the following requirements:

- Tanks have to be located as remote as practicable from accommodation spaces, escape routes, embarkation stations and machinery spaces.
- Tanks have to be isolated by cofferdams from areas containing sources of ignition.
- No fuel tanks are to be arranged forward of the collision bulkhead.
- Aviation fuel tanks may not be arranged directly at the shell. They shall not have common boundaries with tanks not containing aviation fuel.
- The fuel storage area should be provided with arrangements whereby fuel spillage may be collected and drained to a safe location.

6.2.3 Tank equipment

6.2.3.1 The filling and outlet pipes, the sounding equipment, the mounting of devices and fittings as well as the ventilation and overflow equipment has to be provided in accordance with [Section 1, C](#).

6.2.3.2 If the flash point of the fuel is below 60 ° C the following requirements have to be complied with:

- Venting pipes have to be provided with pressure vacuum valves and flame arrestors of approved type. The openings to the atmosphere have to be located at least 3 m away from any source of ignition, openings to accommodation, ventilation inlets and outlets.
- Electrical equipment has to be explosion-protected.

6.3 Fuel transfer system

6.3.1 General

6.3.1.1 For the handling of aviation fuel on board, separate piping systems are to be provided, which are not connected to other fuel systems. It is assumed that the refuelling is done on the helicopter landing deck.

6.3.1.2 The following functions are required:

- filling of the yacht's aviation fuel tank(s)
- discharging from any of the tanks via the connections, with the fuel transfer pump
- transfer of fuel between any of the aviation fuel tanks, using the transfer pump, if applicable
- refuelling of the helicopter from the aviation fuel tank, using the refuelling pump

- flushing of the refuelling hoses to the aviation fuel tank

6.3.2 Piping and pumping arrangements

6.3.2.1 The tank outlet valve has to be directly at the tank. It has to be a quick-closing valve capable of being closed remote-controlled.

6.3.2.2 The piping and the valves have to be made of steel or equivalent material.

Piping connections have to be of approved type.

6.3.2.3 Compensators and hoses have to be of steel or have to be flame-resistant and have to be of approved type.

6.3.2.4 Piping and pumping arrangements have to be firmly connected with the hull structure.

6.3.2.5 The pump has to be able to be controlled from the refuelling station.

6.3.2.6 A relief device has to be provided which prevents over-pressure in the refuelling hose.

6.3.2.7 The following items have to be provided in the system:

- fuel metering
- fuel sampling
- filters
- water traps

6.4 Requirements for the room containing the pump and filter unit (pump room)

The following requirements have to be met:

- The bulkheads and decks have to be of steel and have to be insulated to "A 60" standard towards adjoining spaces.
- Access to the room is only permitted from the open deck. There is no access permitted to other spaces from this room.
- The room has to be provided with a fire detection system and a fixed fire extinguishing system which can be released from outside the room.
- The room has to be provided with a mechanical ventilation of the extraction type which is separate from any other ventilation system. The fans have to be of non-sparking design. The capacity of the ventilation has to be sufficient for 20 air changes per hour, based on the gross volume of the room.
- Inside the room only explosion protected equipment is permitted (IIA, T3).
- Drip trays have to be provided below components where leakages can occur.

- Outside the room, up to a distance of 3 m from openings to the room, possible sources of ignition and openings to other rooms containing possible sources of ignition are not permitted.
- An emergency shutdown of the pumps and release of the quick-closing valves have to be provided from a position located outside the pump room close to the refuelling station.

G. Systems for Breathing Gases and Diving

1. General rules and instructions

1.1 General

1.1.1 Especially the requirements for systems for breathing gases will be defined in the following.

1.1.2 The requirements defined in G. are valid for diving systems and systems for production, bottling and storage of breathing gases if they are to be classified by GL. For such systems the Character of Classification **TAZ** will be assigned, see also [Part 0 – Classification and Surveys, Section 2, C](#).

1.1.3 If fixed diving systems are to be installed on board, such systems have to be manufactured and installed according to the GL Rules, Part 5 – Underwater Technology, Chapter 1 – Diving Systems and Diving Simulators, Section 2.

1.1.4 For the installation of diving compression chambers the GL Rules, Part 5 – Underwater Technology, Chapter 1 – Diving Systems and Diving Simulators, Section 4 have to be applied.

1.1.5 For the manufacturing and operating of underwater equipment the GL Rules, Part 5 – Underwater Technology, Chapter 3 – Underwater Equipment have to be applied.

1.1.6 Designs differing from these Rules may be permitted provided their suitability has been verified by GL and they have been recognized as equivalent. In these cases GL is entitled to require the submission of additional documentation and the performance of special tests.

1.1.7 National regulations existing alongside the GL Rules are unaffected.

1.2 Definitions

1.2.1 Breathing gases, breathing gas mixture

Breathing gases and breathing gas mixtures are all gases and gas mixtures which are used during diving missions respectively during use of breathing apparatus.

1.2.2 Bottles, gas cylinders

Bottles and gas cylinders are pressure vessels for the storage and transport of breathing gases under pressure.

1.2.3 Bottling plant

Bottling plants are used for filling of pressure vessels for breathing gases. This plant includes the complete equipment to fill the bottles. The plant begins immediately behind the closing valve at the pipeline for the gas to be bottled or at the suction socket of the transfer system.

1.2.4 Nitrox

Nitrox is a mixture of breathing gases from compressed air and oxygen with an oxygen content of above 22 %.

1.3 Documents for approval

1.3.1 Before the start of manufacture, plans and drawings of all components subject to compulsory inspection, to the extent specified below, are to be submitted to GL in triplicate:

- Piping diagrams, block diagrams and descriptions are to be furnished for the entire gas supply system and/or bottling plant.
- description of compressors and compressor drives including longitudinal and transverse sectional drawings of the compressors
- drawings of pressure vessels and apparatus giving full details for appraising the safety of the equipment

Approvals of other institutions may be taken into consideration.

1.3.2 The drawings must contain all data necessary to check the equipment's design including information such as pressure ranges, set pressures of safety valves, etc. Wherever necessary, calculations relating to components and descriptions of the system are to be submitted.

1.4 Marking

1.4.1 Permanently installed gas bottles, gas containers and gas piping systems are, in addition, to be marked with a permanent colour code in accordance with Table 3.10 and with the chemical symbol designating the type of gas concerned. The marking of gas bottles must be visible from the valve side.

1.4.2 Gas bottles, gas containers and gas piping systems for nitrox have to be marked separately with a colour code and have to be provided with the designation "Nitrox".

Table 3.10 Marking of gas systems

Type of gas	Chemical symbol	Colour code
Oxygen	O ₂	white
Nitrogen	N ₂	black
Air	—	white & black

1.4.3 Manometers for oxygen and/or nitrox have to be marked as free of oil and grease.

2. Principles for the design and construction of systems for breathing gases

2.1 General principles

2.1.1 Bottling plants are to be constructed and operated in a way that the operating, control and maintenance personnel or other persons in the proximity of the plant are not endangered.

2.1.2 Pipe connections between pressured air bottling plants for the production of breathing gases and other compressed air systems on board are only to be established with special approval of GL and under consideration of additional protection measures.

2.1.3 Pipelines carrying gas or oxygen under high pressure shall not be routed through accommodation spaces, engine rooms or similar compartments.

2.1.4 Pipelines for mixed gases containing more than 25 % oxygen are to be treated as pure oxygen lines.

2.1.5 Filling pipes and intermediate or coupling pieces of filling pipes must be suitable to be released of pressure without danger.

2.1.6 Filling connections are to be constructed or marked in a way that confusion of the gases to be filled is safely avoided and a correct connection can be established.

2.1.7 At the gas draw-off position the bottling plant has to be equipped with a manometer which shows the supply pressure.

2.2 Pressure vessels and apparatus

Pressure vessels and apparatus under pressure are to be designed and manufactured according to the reference in [Section 1, C](#).

2.3 Compressors

2.3.1 The compressors must be suitable for an operation on board of seagoing yachts and are to be

operable under the actual operating and ambient conditions of the yacht.

2.3.2 Compressors are to be designed for the required delivery rates, types of gas and delivery pressures.

2.3.3 Compressors are to be so designed that no lubricating oil can penetrate the gas circuit.

2.3.4 Compressors are to be so installed that no harmful gases can be sucked in.

2.3.5 Oxygen compressors are to be installed in separate spaces with adequate ventilation.

2.3.6 Compressors must be equipped with adequately designed suction filters, coolers and water separators.

2.3.7 The breathing air produced by the compressors must fulfil the requirements of EN 12021. National regulations are unaffected from this.

2.3.8 Each compressor stage must be equipped with a pressure relief valve or rupture disc, neither of which can be disabled. This safety device must be designed and set in such a way that the specified pressure in the compressor stage concerned cannot be exceeded by more than 10 %. The setting must be safeguarded against unauthorized alteration.

2.3.9 Each compressor stage must be provided with a suitable pressure gauge indicating clearly the final pressure of that stage.

2.3.10 Where a compressor stage comprises more than one cylinder and each cylinder can be closed off individually, a pressure relief valve and a pressure gauge must be provided for each cylinder.

2.3.11 Dry-running reciprocating compressors must be equipped at each stage with a device which activates a warning signal and shuts down the drive motor if the final compression temperature stated in the operating instructions is exceeded.

2.3.12 Diaphragm-type compressors must be equipped at each stage with a diaphragm rupture indicator which shuts down the compressor as soon as damage occurs to the drive or compressor diaphragm.

2.3.13 Marking

A manufacturer's data plate containing the following details must be permanently fixed to each compressor:

- type designation
- manufacturer's name
- serial number

- year of manufacture
- flow mass
- delivery pressure
- revolutions per minute

2.4 Piping systems

2.4.1 Piping systems are to be constructed and manufactured on the basis of standards generally used in shipbuilding.

As far as it is not defined in detail in the following, pipelines of bottling plants have to fulfil the requirements according to the reference in [Section 1, C](#).

2.4.2 Expansion in piping systems is to be compensated by pipe bends or compensators. Attention is to be given to the suitable location of fixed points.

2.4.3 Means must be provided for the complete evacuation, drainage and venting of pipelines.

2.4.4 Pipelines which in service may be subject to pressures higher than the design pressure must be fitted with overpressure protection.

2.4.5 The use of hoses is to be restricted to a minimum and only short lengths have to be installed.

2.5 Pipe connections

2.5.1 Wherever possible, pipes should be joined by full-penetration butt welds.

2.5.2 Screwed pipe connections may only be made using bite joints approved by GL.

2.5.3 Flanged connections may be used provided that the flanges and flange bolts conform to a recognized standard.

2.6 Valves and fittings

2.6.1 Shut-off devices must conform to a recognized standard. Valves with screw-down bonnets or spindles are to be protected against unintentional unscrewing of the bonnet.

2.6.2 Manually operated shut-off devices are to be closed by turning in the clockwise direction.

2.6.3 Oxygen lines may only be fitted with screw-down valves, although ball valves may be used for emergency shut-off purposes.

2.6.4 Hose fittings are to be made of corrosion-resistant material and are to be so designed that they cannot be disconnected accidentally.

2.7 Materials

2.7.1 Materials must be suitable for the proposed application and must conform to the GL Rules II – Materials and Welding, Part 1 and 2.

2.7.2 Welds are to conform to the GL Rules, [II-Materials and Welding, Chapter 3 – Welding in the Various Fields of Application, Section 4](#).

2.7.3 Materials for breathing gas systems shall not form any toxic or combustible products.

2.7.4 In oxygen systems, only those materials may be used which are approved for use with oxygen and which are suitable for the proposed operating conditions.

2.8 Electrical installation

The electrical installation has to meet the requirements of [Section 1, D](#).

Systems for breathing gases are to be provided with a sufficient compensation of electrical potential.

2.9 Control and monitoring

Bottling plants for breathing gases have to be operated and monitored manually.

2.10 Additional requirements for breathing gas systems for nitrox and oxygen

2.10.1 Fittings for oxygen are to be constructed to avoid a burn-off or are to be so arranged or protected that the personnel can not be hurt in case of a burn-off.

2.10.2 Spindle valves for oxygen have to be constructed for a nominal diameter above 15 mm and operating pressures of more than 40 bar in a way that the spindle thread is outside of the gas space.

2.10.3 Tightening materials containing combustible elements and which come into contact with compressed gases with oxidizable effects are only approved for fittings if the suitability for the pressures, temperatures and type of installation is proven.

2.10.4 For oxygen armatures and fittings only lubricants are allowed which are approved for the actual operating conditions.

2.10.5 Hoses must be suitable for oxygen.

3. Fire protection and safety

3.1 Arrangement of systems for breathing gases

3.1.1 Production and bottling plants for breathing gases are not to be installed in areas where internal combustion engines or boilers are operated.

3.1.2 Production and bottling plants for breathing gases have to be installed with sufficient space for operation, maintenance and cleaning, for escape and safety routes as well as for fire fighting.

3.1.3 Closed spaces for bottling plants are to be provided with a mechanical ventilation of at least 8 air changes per hour. The air must be sucked from an area which is not endangered by explosion.

3.1.4 Spaces where breathing gas systems for oxygen and/or nitrox are installed have to be provided with fire warning devices.

Floor drainage has to be avoided.

3.1.5 Compressed gas from pressure release and safety devices has to be carried off safely.

3.2 Gas storage

3.2.1 The breathing gases have to be stored in a fixed gas storage or at a suitable place for gas cylinders.

3.2.2 Oxygen gas cylinders are to be stored at well ventilated locations, preferably in suitable cabinets at the open deck and shall not be stored near combustible materials.

3.2.3 Spaces in which oxygen is stored must be separated from the adjoining spaces by bulkheads and decks of an "A 60" class standard and must be arranged to facilitate speedy exit in case of danger. Spaces where oxygen can penetrate are to be equipped with an oxygen monitoring device. The oxygen sensor has to be installed near the floor. As an alternative a monitored suction of the space air may be provided near the floor.

4. Tests and trials

4.1 General

Systems for breathing gases are subject to constructional and material tests as well as to pressure and tightness tests and trials. All the tests called for in the following are to be performed under GL supervision.

4.2 Pressure vessels and apparatuses

Vessels and apparatuses under pressure are to be checked and tested according to the reference in [Section 1, C](#).

4.3 Compressors

4.3.1 Compressor components subject to pressure are to undergo a hydraulic pressure test at a test pressure equal to 1,5 times the delivery pressure of the compressor stage concerned.

4.3.2 On completion, compressors are to be subject to a tightness test at their maximum working pressure. In addition, a performance test is to be carried out in which the final moisture content and any possible contamination of the compressed gas are to be determined.

4.3.3 Compressor plants have to undergo a functional test after their completion, which has to include a check of the control, monitoring and safety equipment.

4.4 Pipes and fittings

4.4.1 After completion, but before insulation and painting all pipes and fittings have to undergo a pressure test with 1,5 times the design pressure.

4.4.2 Pipes and fittings for breathing gases and oxygen have to be cleaned before putting into operation and have to undergo a cleanness test.

4.4.3 For fittings in oxygen and/or nitrox lines the oxygen suitability has to be proven.

4.5 Hoses

4.5.1 The bursting pressure of each hose type has to be proven to GL, whereby for gases at least 5 times the maximum permissible working pressure has to be endured.

4.5.2 Each hose is to be subjected to a hydraulic pressure test at least 2 times the maximum permissible working pressure.

4.6 Electrical equipment

Electrical machines, components, cables and lines as well as the electrical protection equipment are to be tested in the manufacturer's works in accordance with [Section 1, E](#).